



AVENTOS

An inspiring range of lift systems

m.com

Perfecting motion  **blum**[®]



blum



Ease of

motion – multitude of options

The AVENTOS lift system brings ease of motion to the wall cabinet. Even large and heavy lift systems can be opened with the utmost ease. What makes AVENTOS especially practical is that it offers the furniture user full freedom of movement and provides the necessary cabinet access at all times. Your customers will be inspired.

Contents

- 4 Lift system range
- 5 Ideas for practical kitchens
- 6 The lift system programme
- 8 Motion technologies
- 10 Top quality
- 12 Assembly
- 14 Frequently asked questions
- 16 Design
- 18 AVENTOS HF
- 34 AVENTOS HS
- 42 AVENTOS HL
- 50 AVENTOS HK
- 64 AVENTOS HK-S
- 72 Blum transformer and accessories
- 74 SERVO-DRIVE for AVENTOS functions
- 80 Blum

The lift system programme

They fold, lift and swing up and over with fascinating ease

AVENTOS is the ideal solution for any wall cabinet. Whether it is used in the kitchen or living area, whether there is lots of space available or only a little and whether it is used with small or large fronts, one thing never changes: the supreme ease of motion. Thanks to integrated BLUMOTION, lift systems always close silently and effortlessly. Combined with SERVO-DRIVE, lift systems will open with a light touch and close automatically with a press of a button.

In addition to their proven stability and elegant design AVENTOS lift systems offer a complete solution for all round high level movement.



Bi-fold lift system

AVENTOS HF

- Ideal for high wall cabinets
- Handle is easy to reach, even when the lift system is open
- Takes up minimal space even when large cabinet heights, thanks to the two-part front
- Can be used with fronts of different heights
- Variable stop

Up & over lift system

AVENTOS HS

- Ideal for large, one-part fronts
- Minimal space required thanks to swivel motion
- Can be combined with cornice or crown moulding
- No hinges required
- Variable stop

Lift up

AVENTOS HL

- Ideal for tall or wall cabinets with fronts above or for recessed cabinets.
- Suitable for smaller, one-piece and even low fronts
- Easy access to storage items
- No hinges required
- Variable stop



Stay lift AVENTOS HK

- Ideal for small and medium wall cabinets
- The space requirement above cabinets is reduced by the lift system motion
- No hinges required
- Variable stop

Small stay lift

AVENTOS HK-S

- Perfect for small cabinets, e.g. over refrigerators or larder units
- Harmonious proportions
- No hinges required
- Variable stop

DYNAMIC SPACE



DYNAMIC SPACE – Ideas from Blum for practical kitchens
Good workflows, enough storage space and top quality motion. For Blum, workflow, space and motion are the three essential features of a practical kitchen. With DYNAMIC SPACE, we offer helpful ideas, suggestions and solutions so that today's kitchens don't just look great, but are practical as well.

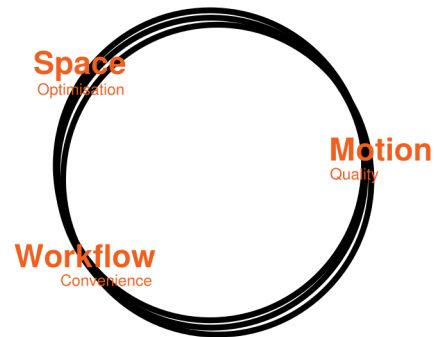

Workflow – Easy access
With AVENTOS, the front moves up, taking it right away from the work area. This makes the cabinet contents easy to access at all times. If the cabinet is placed near the dishwasher, clean glasses can be put back in their rightful place at lightning speed.



Space – Fits in with storage space requirements
Wall cabinets with lift systems are flexible with regard to size. The optimum size depends on your room layout, your individual storage space requirements and your aesthetic preferences. Depending on the lift system type, heights of approx. 185 mm to 1040 mm are possible, coupled with widths ranging from 300 mm to 1800 mm.



Motion – New effortlessness for lift systems
Even heavy and wide fronts have a feather-light glide. Regardless of the force applied, all AVENTOS lift systems always close silently and effortlessly – thanks to BLUMOTION. With SERVO-DRIVE, the electrical motion support system, lift systems open with just a light touch and close at the touch of an easily accessible switch.

The lift system programme

Everything at a glance

The graphic below shows how the five fittings from the AVENTOS range can be used in a common kitchen system.



*AVENTOS is flexible enough to be used in wall cabinets using 4-tier systems in addition to the 6-tier system shown above.



HF HS HL HK HK-S

Area of application

High wall cabinets	■	■			
Medium wall cabinets	■	■	■	■	
Low wall cabinets			■	■	■
Tall cabinets			■	■	■

Room planning

Min. top space requirement	■	■		■	■
----------------------------	---	---	--	---	---

Design

Single front		■	■	■	■
Two-part front	■				
Can be combined with cornice or crown moulding	■	■	■	■	■
Cabinet height dimensions in mm	480-1040	350-800	300-580	up to 6001	up to 400
Cabinet width dimensions in mm	up to 1800	up to 1800	up to 1800	up to 1800	up to 18002

Ergonomics

Handles within easy reach	■	■	■	(■)	(■)
Easy access to cabinet interior	■	■	■	■	■

Motion technologies

BLUMOTION	■	■	■	■	■
SERVO-DRIVE	■	■	■	■	
TIP-ON				■	

3

¹ For ergonomic reasons, we recommend a maximum cabinet height of 600 mm. However, higher lift systems can also be implemented subject to the power factor limits (see page 54).

² Cannot be combined with BLUMOTION

³

Fascinating ease of motion for lift systems

With its innovative motion technologies, Blum not only makes opening and closing lift systems easier – it turns the process into an experience.



BLUMOTION

Soft and effortless closing

BLUMOTION is synonymous with fascinating quality of motion. Allow your customers to see for themselves – they will be inspired

Compatible with



SERVO-DRIVE

Unsurpassed ease of use

A single touch suffices and the lift system opens as if by magic. To close, simply press the easy-to-access switch on the inside of the cabinet.



TIP-ON

Simply press the lift system and it opens

TIP-ON for AVENTOS HK our mechanical opening support system, now makes handle-less fronts easy and comfortable to open.

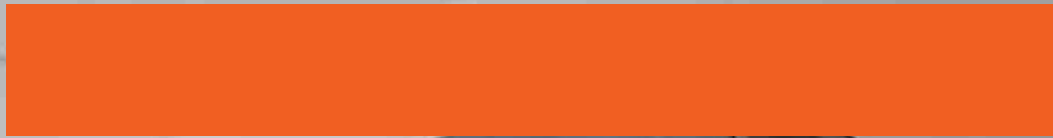

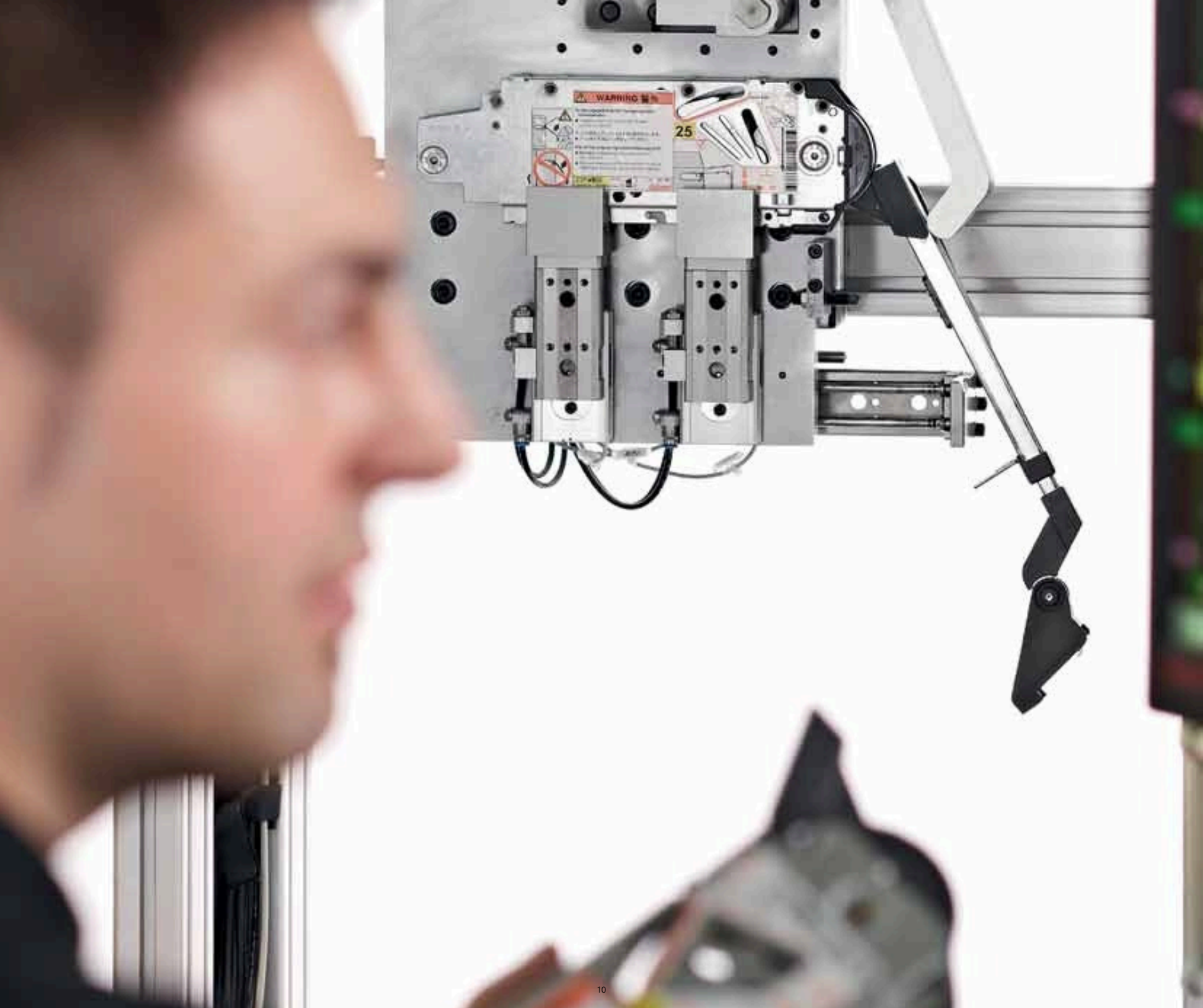

Reliability – a furniture lifetime



We want our fitting solutions to provide your customers with many years of enjoyment and satisfaction.

That is why we focus on ensuring the highest quality:

Precision testing

Each fitting is tested extensively according to strict criteria. Testing is carried out at our own test labs as well as in conjunction with international testing organisations. An AVENTOS lift system goes through the opening and closing process up to 80,000 times which is double the industry requirement – only then are we satisfied in terms of quality.

Long warranty

Our promise to provide “quality a furniture lifetime” naturally applies to AVENTOS as well. We are so confident of this that we also offer you a full 5-year warranty in respect of all the electrical components e.g. SERVO-DRIVE when used in combination with Blum products.

Meticulous selection and processes High-quality robust materials. Exact assembly. Fast and simple assembly. From the choice of material right through to construction and start-up, we insist on consistently high levels of quality.



A close-up, profile view of a person with short dark hair, smiling and looking towards the right. They are wearing a light blue shirt. In the background, a mechanical assembly is visible, featuring a silver metal bracket and a complex internal mechanism with various components, including a circular part and a barcode. The scene is brightly lit, suggesting an indoor setting with large windows.

Easy insertion: Assembly of the cross stabiliser for AVENTOS HS and AVENTOS HL is now completely tool-free.

Just a few simple steps are required



Almost entirely tool-free AVENTOS can be assembled with ease and the proven CLIP technology makes the process almost entirely tool-free. The only tool required is a power screwdriver for adjusting the lift mechanism in precise accordance with the front weight. The fact that the cross stabiliser for AVENTOS HS is attached without tools significantly reduces the amount of effort required for assembly. Fronts can be conveniently adjusted in 3 dimensions to ensure perfect gap alignment.

SERVO-DRIVE: Start-up made easy SERVO-DRIVE for AVENTOS only has a few components. These are easy to attach and can be precisely adjusted. In just a few simple steps, SERVO-DRIVE can be assembled, cable added, switch installed and the system can be put into operation.

Find out more about
SERVO-DRIVE



AVENTOS

Why is it that the lift system rises or falls when you let go?

This occurs when the lift mechanism has not been set correctly. The fine adjustment process involves using a power screwdriver and the integral calibration to adjust the lift mechanism in precise accordance with the front weight. The result: The front stays in the position required.

Is it also possible to use opening angle stops?

Yes, it is possible for AVENTOS HF, HK and HK-S. In the case of SERVO-DRIVE for AVENTOS, the drive unit must be mounted first and once the opening angle stop has been subsequently mounted, a reference run must be performed.

Can the AVENTOS concept be implemented without using handles?

Yes, you can equip the lift system with SERVO-DRIVE (an electrical motion support system) or TIP-ON (a mechanical opening support system). A single touch suffices and the lift systems appear to open by themselves.

SERVO-DRIVE for AVENTOS

Is it possible to synchronise multiple lift systems?

Yes. Up to three drive units can be set so that they move simultaneously. This is especially practical in cases where there is a shared front covering several cabinets. In addition, the "collision avoidance" function for corner solutions allows you to adjust the drive units so that only one front ever opens at a time.

What does my customer see when the wireless switch battery has to be replaced?

The SERVO-DRIVE switch contains a battery display. It flashes red when the battery power begins to weaken. Battery replacement is very simple. All you need is a conventional button cell battery (type CR 2032).

What happens when the power goes out?

When there is a power cut SERVO-DRIVE for AVENTOS is not activated. However, you can continue to open and close manually without restrictions. Once the power has been restored, you can carry on using everything as normal without having to reset the SERVO-DRIVE unit.

Can SERVO-DRIVE for AVENTOS be deactivated?

Your customers can deactivate SERVO-DRIVE for AVENTOS very easily. This is especially practical when cleaning the fronts, for example. We recommend a switched outlet for this. While deactivated, the lift systems can continue to be opened and closed manually.



Award-winning design

Enchanting Elegance

Along with high functionality, the AVENTOS range is sure to inspire through its simple yet elegant design. The fact that it has received a number of international awards is testament to this.





A vast array of options for wall cabinets

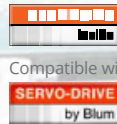

Compatible with.

SERVO-DRIVE
by Blum

The AVENTOS HF bi-fold lift system is the ideal solution for high and mid wall units. Thanks to the two-part front, even high cabinets can be accommodated. With AVENTOS HF, there is no limit to the variety of planning and design options available. Whether your customers want wooden fronts, narrow or wide aluminium frames, combinations of different materials or even fronts of different heights, you will always be able to meet their individual requirements. Handle-less fronts can be opened using SERVO-DRIVE technology.



Watch video of the assembly and adjustment processes



Greater freedom of design: AVENTOS HF allows you to combine different materials for the lift system front.



Innovative technology that offers protection: The CLIP top centre hinge prevents fingers getting caught.



At the heart of this fitting solution is the lift mechanism with BLUMOTION and a robust spring package.

AVENTOS HF

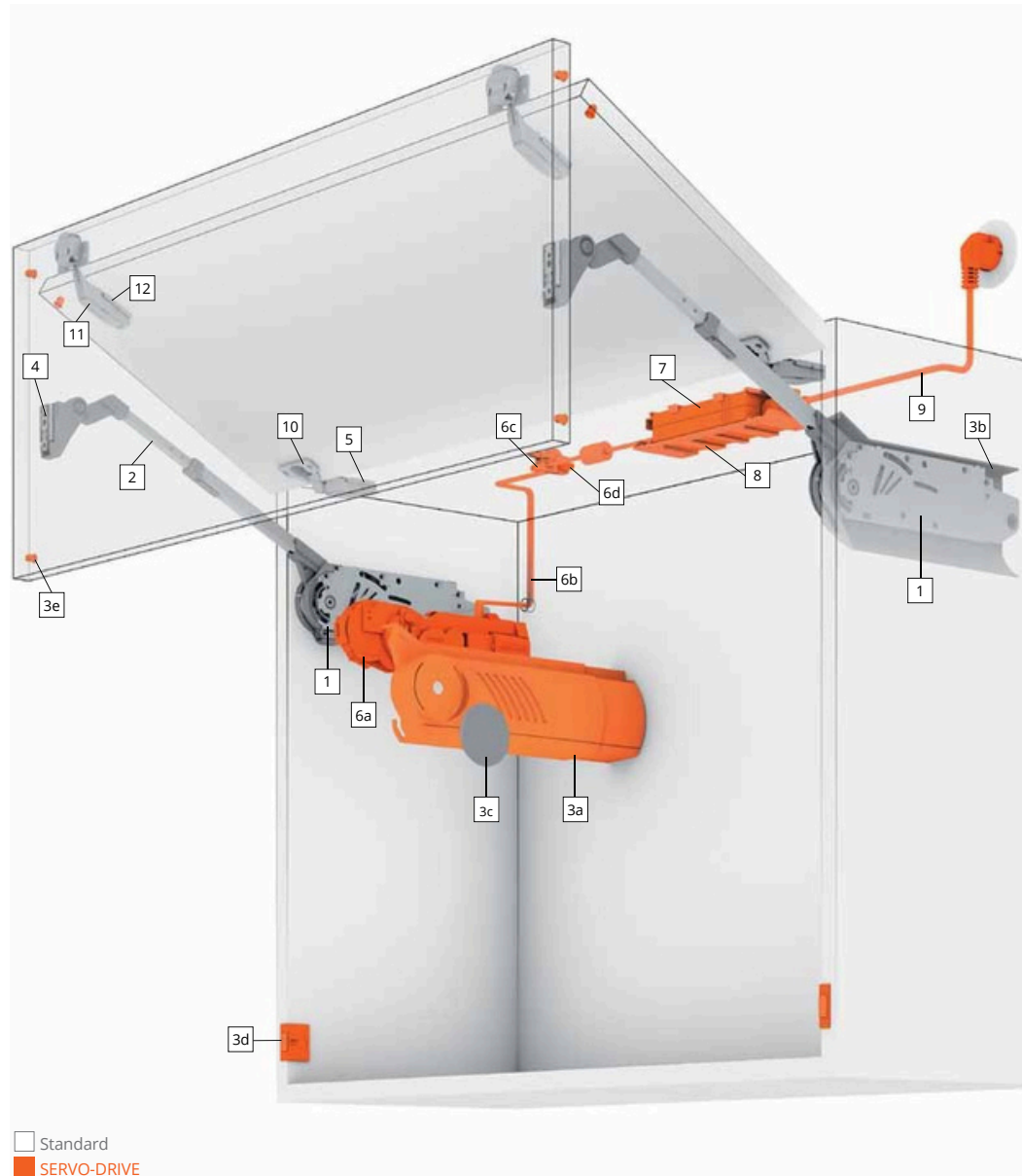



- 1** Lift mechanism
- 2** Telescopic arm
- 3a** Cover cap, left
The left SERVO-DRIVE cover cap is used to cover the lift mechanism, drive unit and distribution cable. To cover the cabling, the cover cap can be expanded up to an internal depth of 350 mm.
- 3b** Cover cap right
- 3c** Cover cap round
- 3d** SERVO-DRIVE switch
The SERVO-DRIVE switch is attached to the cabinet side at the bottom. The switch signals the drive unit via a wireless connection. The 2.4 GHz frequency is certified for international use.
- 3e** Blum distance bumper
The Blum distance bumper creates and maintains the required trigger path of 2 mm.
- 4** Mounting plate for telescopic arm
- 5** Mounting plate for CLIP top 120° hinge
12 CLIP top centre hinge
- 6a** Drive unit
The drive unit is attached without tools to the left lift mechanism. The same drive unit can be used for all lift mechanisms.
- 6b** Distribution cable
This cable is used to supply power to the drive unit. The maximum permitted operating power is 24 V.
- 6c** Connecting node + cable end protector
6d This node establishes the electrical connection between the distribution cable and the transformer. The cable end protector is inserted into the "open" end of the cable.
- 7** Blum transformer + flex
9 The Blum transformer can be used worldwide. It converts the country-specific mains voltage to 24 V direct current. You must use a flex with a regular plug for the respective country depending on the installation location.
- 8** Transformer unit housing
The transformer is easily and securely stored in the transformer unit housing.
- 10** CLIP top 120° hinge (unsprung)
- 11** CLIP top centre hinge

Order information Standard and SERVO-DRIVE for AVENTOS HF

Wooden fronts and wide aluminium frames symmetrical/asymmetrical

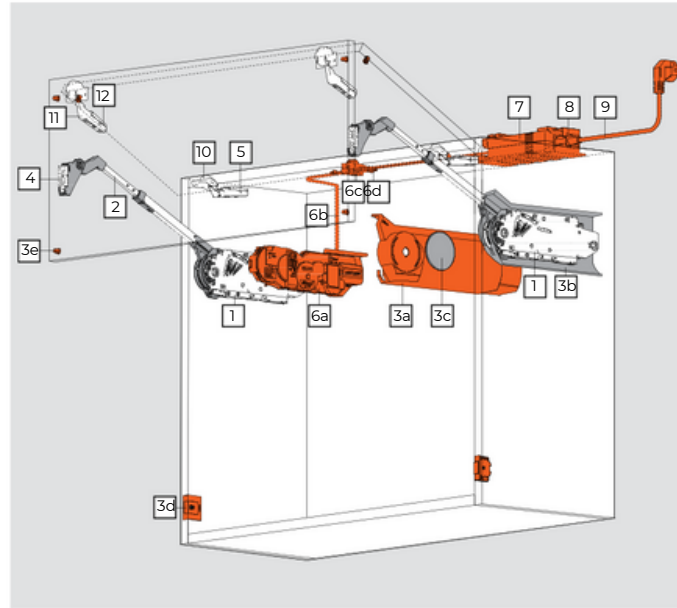

3 types of lift mechanisms are enough to cover a wide range of applications.

Using the power factor, you can calculate the number of required lift mechanisms. The power factor required depends on the weight of the lower and upper front and the cabinet height. The power factor and the door weight can be increased by 50 % when a third lift mechanism is used.

The larger front must be at the top for asymmetrical fronts.

□ Standard
■ SERVO-DRIVE

i Power factor LF = cabinet height KH (mm) x front weight bottom and top incl. handle (kg)

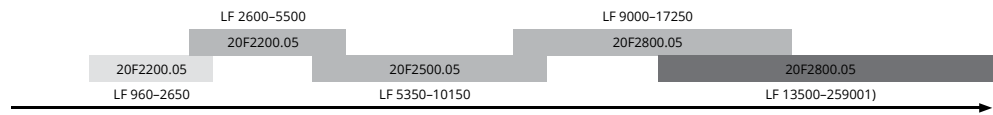

□ Lift mechanism one-sided ■ Lift mechanism two-sided ■ Additional 3rd lift mechanism lift mechanism LF Power factor



A trial application is recommended when you are in a borderline area of the individual lift mechanism.

¹⁾ We recommend two synchronised drive units for a power factor > 17250.

1	Lift mechanism set	2	Telescopic arm set
	Power factor LF		Nickel plated steel
	2600-5500 (1 piece LF 960-2650)		Cabinet height ²⁾ 480-570 mm
	5350-10150		Cabinet height ²⁾ 560-710 mm
	9000-17250 (3 pieces LF 13500-25900)		Cabinet height ²⁾ 700-900 mm
Composed of:		Cabinet height ²⁾ 760-1040 mm	
2 x symmetrical lift mechanisms		Composed of:	
10 x chipboard screws Ø 4 x 35 mm		2 x symmetrical telescopic arms	
		²⁾ "Theoretical cabinet height" for asymmetrical fronts = front height top (FHO) x 2 (incl. gaps)	



	3	Cover cap set		
		Nylon		
		light grey, silk white,		20F8000
		Composed of:		
3a		1 x cover cap large left		
3		1 x cover cap large right		
b		2 x round cover caps		
3c				
	3	Cover cap set for SERVO-DRIVE		
		Nylon		
		light grey, silk white,		21F8 0 0 0
		Composed of:		
3a		1 x SERVO-DRIVE cover cap large left		
3		1 x cover cap large right		
b		2 x round cover caps		
3c		2 x SERVO-DRIVE switches		
3		6 x Blum distance bumpers, Ø 5 mm		
d				
	6	SERVO-DRIVE set		
		Nylon		
		RAL 7037 dust grey		21FA 0 0 0
		Composed of:		
6a		1 x drive unit		
6		1 x distribution cable, 1500 mm		
b		1 x connecting node		
6c		2 x cable end protectors		
6				
d				
		Opening angle stop		
		Nylon 104° 83°		
		Dark grey	2 x	20F7051
		Dust grey	2 x	20F7011

		Hinge set		
		for wooden fronts		
		Fixing method: INSERTA/EXPANDO/knock in		78Z5530T10
		Comprising of:		
10 11		2 x CLIP top 120° hinge o. F.3) (70T55908TL)		
4, 5, 12		2 x CLIP top centre hinge (78Z5530T)		
12		6 x Horizontal cam mounting plate (177H5100)		
		2 x Cruciform mounting plate (174E6100.01)		
		³⁾ o. F. = unsprung		
		Hinge set		
		for wooden fronts and wide alu frames		
		Fixing method: Screw-on4)		78Z5500T11
		Comprising of:		
10 11		2 x CLIP top 120° hinge o. F.3) (70T5550.TL)		
4, 5, 12		2 x CLIP top centre hinge (78Z5500T)		
12		6 x Horizontal cam mounting plate (175H5400)		
		2 x Cruciform cam mounting plate (173H7100)		
		³⁾ o. F. = unsprung		
		⁴⁾ Use chipboard screws (609.1x00) for wooden fronts. Use self tapping screw, countersunk head (660.0950) for wide alu frames.		
		Bit PZ cross slot		
		Size 2, length 39 mm		BIT-PZ KS2
	7, 8, 9	Blum transformer, flex and transformer unit housing		
			Page	74

Planning information Standard and SERVO-DRIVE for AVENTOS HF

wooden fronts and wide aluminium frames symmetrical

Drilling position

4 x $\varnothing 4 \times 35$ mm
Drilled hole for SERVO-DRIVE distribution cable, left only

* Drilling depth 5 mm
** Alternative drilling

Cabinet height	H
480-549 mm	KH x 0.3 - 28 mm
550-1040 mm	KH x 0.3 - 57 mm

Space requirement

KH Cabinet height

Front assembly

KH Cabinet height
SFA Side front overlay

Number of hinges
3 hinges starting at cabinet width 1200 mm and/or 12 kg door weight
4 hinges starting at cabinet width 1800 mm and/or 20 kg door weight

Cabinet height (KH)	X	X
480-549 mm	70 mm 47	68 mm 45
550-1040 mm	mm	mm

CLIP top 120° hinge unsprung

F () Drilling distance TB for standard hinge
CLIP top 120° special hinge

Front overlay FA	
	5 6 7 8 9 10 11 12 13 14 15 16 17
0	
3	
6	
9	

▲ Mounting plate

CLIP top centre hinge

Min. gap F = 1.5 mm
* 37 mm for cruciform mounting plates (37/32)

Drilling distance TB

Centre gap F	
	3 4 5 6
0	
3	
6	
9	

▲ Mounting plate



Space requirement

FH Front height
 Opening angle stop
 Without 104° 83° $Y = FH \times 0.44 + 38 \text{ mm}$
 $Y = FH \times 0.24 + 34 \text{ mm}$
 $Y = 0 \text{ mm}$

Screw-on assembly

INSERTA/EXPANDO assembly

Ø 9.5
 35 ± 0.2
 45
 () INSERTA

SERVO-DRIVE switch

Blum distance bumper drilling position

* From cabinet bottom edge for fronts that protrude below the cabinet

Recommendation for aluminium frames: Consider drilling Blum distance bumper holes in the cabinet side. A trial application must be carried out when fixing the Blum distance bumper to the front.

i Do not glue Blum distance bumper.

Blum distance bumper

- Standard
- SERVO-DRIVE

Planning information Standard and SERVO-DRIVE for AVENTOS HF

wooden fronts and wide aluminium frames asymmetrical

Drilling position

4 x Ø 4 x 35 mm
Drilled hole for SERVO-DRIVE distribution cable, left only

* Drilling depth 5 mm
** Alternative drilling

Cabinet height	H
480-549 mm	TKH x 0.3 - 28 mm
550-1040 mm	TKH x 0.3 - 57 mm

Space requirement

TKH Theoretical cabinet height
KH Cabinet height
FHo Front height top
FHu Front height bottom
Theoretical cabinet height (TKH) = front height top (FHo) x 2 (including gaps)

Front assembly

Min. lower front height
 $X + 19 + FAu$
FHo Front height top
TKH Theoretical cabinet height
SFA Side front overlay
FAu Lower front overlay
Number of hinges
3 hinges starting at cabinet width 1200 mm and/or 12 kg door weight
4 hinges starting at cabinet width 1800 mm and/or 20 kg door weight

Theoretical cabinet height (TKH)	X	X
	177H5100	177H5400E
480-549 mm	FHo/2 + 70	FHo/2 + 68
550-1040 mm	mm FHo/2 + 47 mm	mm FHo/2 + 45 mm

CLIP top 120° hinge unsprung

F () Drilling distance TB for standard hinge
CLIP top 120° special hinge

	Front overlay FA															
	5	6	7	8	9	10	11	12	13	14	15	16	17			
0										3	4	5	6			
3							3	4	5	6						
6				3	4	5	6									
9	3	4	5	6												

▲ Mounting plate

CLIP top centre hinge

Min. gap F = 1.5 mm
* 37 mm for cruciform mounting plates (37/32)

Drilling distance TB

	Centre gap F					
	3	4	5	6		
0			3	4	5	6
3			6	5	4	3
6						
9						

▲ Mounting plate



Space requirement

FH Front height
 Opening angle stop
 Without 104° 83° $Y = FH \times 0.44 + 38 \text{ mm}$
 $Y = FH \times 0.24 + 34 \text{ mm}$
 $Y = 0 \text{ mm}$

Screw-on assembly

INSERTA/EXPANDO assembly

SERVO-DRIVE switch

Blum distance bumper drilling position

* From cabinet bottom edge for fronts that protrude below the cabinet

Recommendation for aluminium frames: Consider drilling Blum distance bumper holes in the cabinet side. A trial application must be carried out when fixing the Blum distance bumper to the front.

i Do not glue Blum distance bumper.

Blum distance bumper

- Standard
- SERVO-DRIVE

Order information Standard and SERVO-DRIVE for AVENTOS HF

Narrow aluminium frames symmetrical/asymmetrical

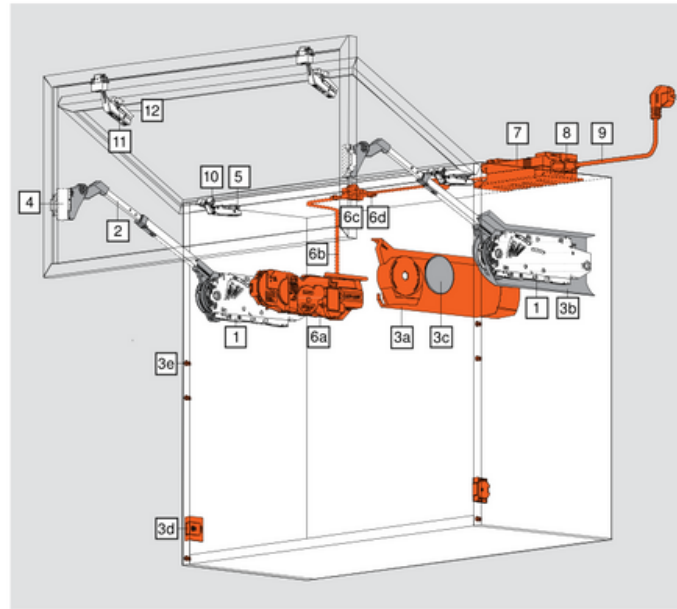

3 types of lift mechanisms are enough to cover a wide range of applications.

Using the power factor, you can calculate the number of required lift mechanisms. The power factor required depends on the weight of the lower and upper front and the cabinet height.

The larger front must be at the top for asymmetrical fronts.

□ Standard
■ SERVO-DRIVE

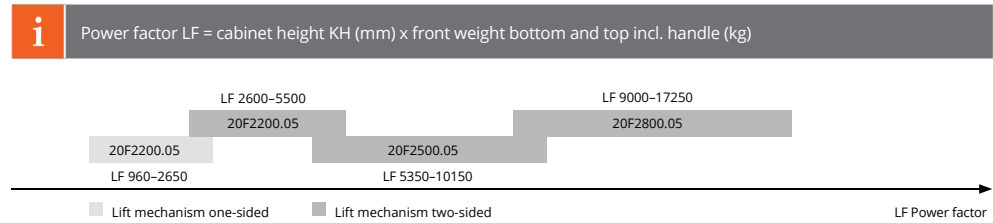

A trial application is recommended when you are in a borderline area of the individual lift mechanism.

	1 Lift mechanism set	
	Power factor LF	
	2600-5500 (1 piece LF 960-2650)	20F2200.05
	5350-10150	20F2500.05
	9000-17250 (3 pieces LF 13500-25900)	20F2800.05
Composed of:		
	2 x symmetrical lift mechanisms	
	10 x chipboard screws Ø 4 x 35 mm	
	2 Telescopic arm set	
	Nickel plated steel	
	Cabinet height ²⁾ 480-570 mm	20F3200.01
	Cabinet height ²⁾ 560-710 mm	20F3500.01
	Cabinet height ²⁾ 700-900 mm	20F3800.01
	Cabinet height ²⁾ 760-1040 mm	20F3900.01
	Composed of:	
	2 x symmetrical telescopic arms	
	²⁾ "Theoretical cabinet height" for asymmetrical fronts = front height top (FHO) x 2 (incl. gaps)	



	3	Cover cap set	
		Nylon light grey, silk white,	20F8000
		Composed of:	
3a		1 x cover cap large left	
3		1 x cover cap large right	
b		2 x round cover caps	
3c			

	3	Cover cap set for SERVO-DRIVE	
		Nylon light grey, silk white,	21F8 0 0 0
		Composed of:	
3a		1 x SERVO-DRIVE cover cap large left	
3		1 x cover cap large right	
b		2 x round cover caps	
3c		2 x SERVO-DRIVE switches	
3		6 x Blum distance bumpers, Ø 5 mm	
d			
3e			

		Bit PZ cross slot	
		Size 2, length 39 mm	BIT-PZ KS2

	6	SERVO-DRIVE set	
		Nylon RAL 7037 dust grey	21FA 0 0 0
		Composed of:	
6a		1 x drive unit	
6		1 x distribution cable, 1500 mm	
b		1 x connecting node	
6c		2 x cable end protectors	
6			
d			

		Hinge set for narrow alu frames Fixing method: screw-on	78Z5500T11
		Comprising of:	
10		2 x CLIP top 120° alu frame hinge o. F.2) (72T550A.TL)	
11		2 x CLIP top alu frame centre hinge (78Z550AT)	
12		2 x CLIP adapter plate symmetrical (175H5A00)	
4		2 x CLIP adapter plate left/right (175H5B00)	
5		2 x Horizontal cam mounting plate (175H5400)	
		²⁾ o. F. = unsprung	

	7, 8, 9	Blum transformer, flex and transformer unit housing	
			Side 74

Planning information

Standard and SERVO-DRIVE for AVENTOS HF

Narrow aluminium frames symmetrical

Standard SERVO-DRIVE

Drilling position

4 x $\varnothing 4 \times 35$ mm
 Drilled hole for SERVO-DRIVE distribution cable, left only

* Drilling depth 5 mm
 ** Alternative drilling

Cabinet height	H
480-549 mm	KH x 0.3 - 28 mm
550-1040 mm	KH x 0.3 - 57 mm

Standard SERVO-DRIVE

Space requirement

KH Cabinet height

Standard SERVO-DRIVE

Front assembly

KH Cabinet height

Number of hinges
 3 hinges starting at cabinet width 1200 mm and/or 12 kg door weight
 4 hinges starting at cabinet width 1800 mm and/or 20 kg door weight

Cabinet height	X	54
480-549 mm		mm
550-1040 mm		31

mm

Standard SERVO-DRIVE

CLIP top 120° alu frame hinge unsprung

Standard SERVO-DRIVE

CLIP top alu frame centre hinge

Min. gap F = 1.5 mm
 An adjustment has to be made for frame thicknesses over 20.5 mm

Standard
 SERVO-DRIVE



Space requirement

FH Front height

Opening angle stop

Without 104° 83°	$Y = FH \times 0.44 + 38 \text{ mm}$
	$Y = FH \times 0.24 + 34 \text{ mm}$
	$Y = 0 \text{ mm}$

Front assembly

* When changing material thickness, adjust the assembly dimensions accordingly

SERVO-DRIVE switch

Blum distance bumper drilling position

Blum distance bumper

* From cabinet bottom edge for fronts that protrude below the cabinet

Recommendation for aluminium frames: Consider drilling Blum distance bumper holes in the cabinet side. A trial application must be carried out when fixing the Blum distance bumper to the front.

i Do not glue Blum distance bumper.

Planning information Standard and SERVO-DRIVE for AVENTOS HF

Narrow aluminium frames asymmetrical

Drilling position

4 x $\varnothing 4 \times 35$ mm
Drilled hole for SERVO-DRIVE distribution cable, left only

* Drilling depth 5 mm
** Alternative drilling

TKH	H
480-549 mm	TKH x 0.3 - 28 mm
550-1040 mm	TKH x 0.3 - 57 mm

Space requirement

min 278

FHO

FHu

TKH

min 72.5.59

min 22

62

89

68

29

SERVO-DRIVE

TKH Theoretical cabinet height
KH Cabinet height
FHO Front height top
FHU Front height bottom
Theoretical cabinet height (TKH) = upper front height (FHO) x 2 (including gaps)

Front assembly

Min. measurement for front height bottom
 $X + 33 + FAU$

FHO Front height top
TKH Theoretical cabinet height
FHU Front height bottom
FAU Lower front overlay
Number of hinges
3 hinges starting at cabinet width 1200 mm and/or 12 kg door weight
4 hinges starting at cabinet width 1800 mm and/or 20 kg door weight

TKH	X
480-549 mm	FHO/2 + 54 mm
550-1040 mm	FHO/2 + 31 mm

CLIP top 120° alu frame hinge unsprung

19.5

15

1.7

19

66.5

CLIP top alu frame centre hinge

21

66

19.5

19.5

3

Min. gap F = 1.5 mm
An adjustment has to be made for frame thicknesses over 20.5 mm



Space requirement

FH Front height

Opening angle stop

Without 104° 83°	$Y = FH \times 0.44 + 38 \text{ mm}$
	$Y = FH \times 0.24 + 34 \text{ mm}$
	$Y = 0 \text{ mm}$

Front assembly

* When changing material thickness, adjust the assembly dimensions accordingly

SERVO-DRIVE switch

Blum distance bumper drilling position

Blum distance bumper

* From cabinet bottom edge for fronts that protrude below the cabinet

Recommendation for aluminium frames: Consider drilling Blum distance bumper holes in the cabinet side. A trial application must be carried out when fixing the Blum distance bumper to the front.

i Do not glue Blum distance bumper.

- Standard
- SERVO-DRIVE



Room for beautiful details



Compatible with.



With the lift system fitting for AVENTOS HS, even large, one-part fronts appear to defy gravity by swinging up effortlessly. There is still enough space over the cabinet for a host of design options, such as beautiful details in the form of cornice or crown mouldings. As you would expect, this product is just as easy to assemble as the others and the process is almost entirely tool-free. Handle-less fronts can be opened using SERVO-DRIVE technology and without any need for hinges.



Watch video of the assembly and adjustment processes



Tailored to your tastes: AVENTOS HS also allows wall cabinets to be decorated with cornice or crown mouldings.

At the heart of this fitting solution is the lift mechanism with BLUMOTION and a robust spring package.

AVENTOS HS

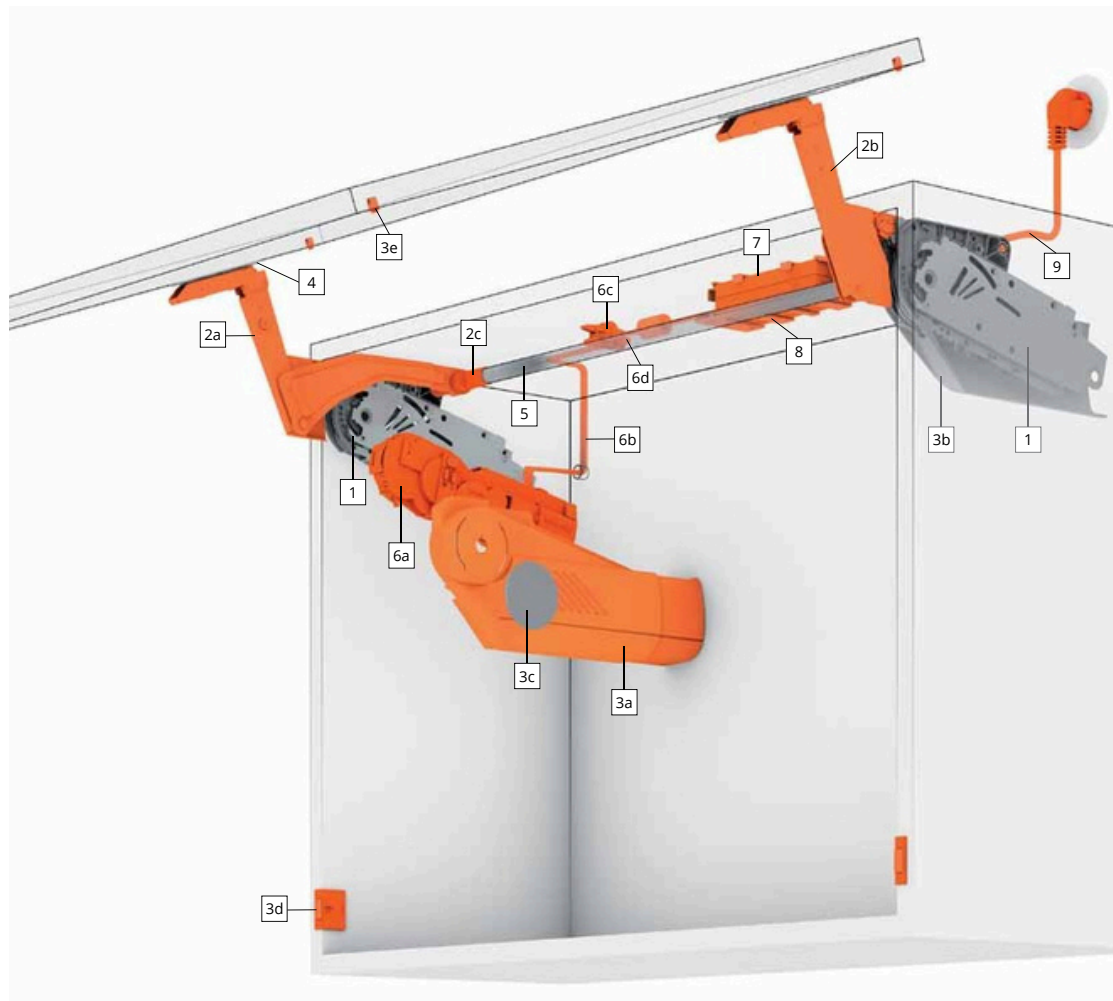

- Standard
- SERVO-DRIVE



- 
- 1** Lift mechanism
 - 2a** Lever arm
 - 2**
b Cross stabiliser cover cap
 - 2c** Cross stabiliser cover cap
 - 3a** Cover cap, left
The left SERVO-DRIVE cover cap is used to cover the lift mechanism, drive unit and distribution cable. To cover the cabling, the cover cap can be expanded up to an internal depth of 350 mm.
 - 3b** Cover cap right
 - 3c** Cover cap round
 - 3d** SERVO-DRIVE switch
The SERVO-DRIVE switch is attached to the cabinet side at the bottom. The switch signals the drive unit via a wireless connection. The 2.4 GHz frequency is certified for international use.
 - 3e** Blum distance bumper
The Blum distance bumper creates and maintains the required trigger path of 2 mm.
 - 4** Front fixing bracket
 - 5** Cross stabiliser rod round
 - 6a** Drive unit
The drive unit is attached without tools to the left lift mechanism. The same drive unit can be used for all lift mechanisms.
 - 6b** Distribution cable
This cable is used to supply power to the drive unit. The maximum permitted operating power is 24 V.
 - 6c** Connecting node + cable end protector
 - 6**
d This node establishes the electrical connection between the distribution cable and the transformer. The cable end protector is inserted into the "open" end of the cable.
 - 7** Blum transformer + flex
 - 9** The Blum transformer can be used worldwide. It converts the country-specific mains voltage to 24 V direct current. You must use a flex with a regular plug for the respective country depending on the installation location.
 - 8** Transformer unit housing
The transformer is easily and securely stored in the transformer unit housing.

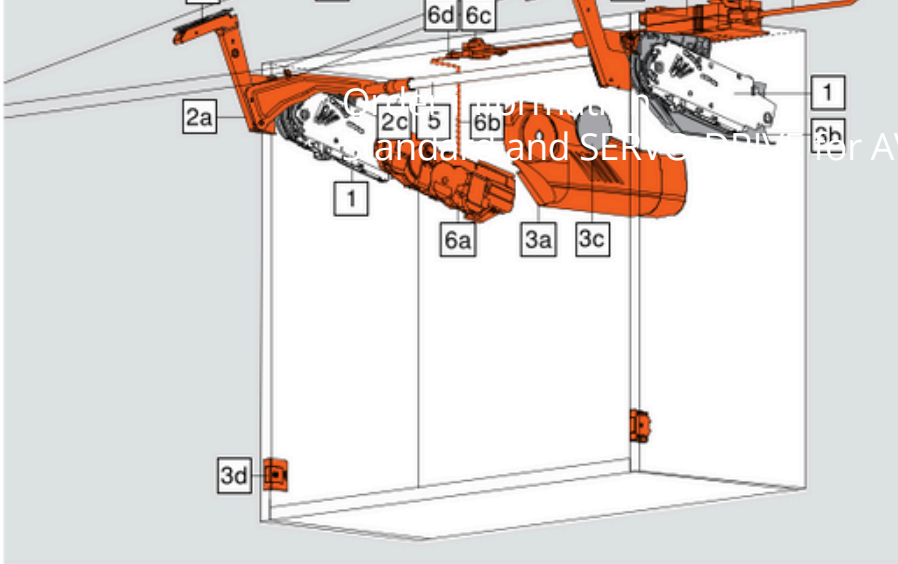

3 Cover cap set for SERVO-DRIVE

Nylon
light grey, silk white

Composed of:

- 3a 1 x SERVO-DRIVE cover cap large left
- 3 1 x cover cap large right
- b 2 x round cover caps
- 3c 2 x SERVO-DRIVE switches
- 3 4 x Blum distance bumpers, Ø 5 mm
- d
- 3e

4 Front fixing bracket set

Nickel plated
Wooden fronts and wide aluminium frames1)

20S42E1

Narrow alu frames

1) Use 4 chipboard screws (609.1x00) per side for wooden fronts. Use 4 countersunk self tapping screws (660.0950) per side for wide aluminium frames.

5 Cross stabiliser rod round

Aluminium, Ø 16 mm

For cutting to size, 1061 mm

20Q1061UN

Cutting: LW - 129 mm

SERVO-DRIVE: LW - 164 mm

Connecting piece set for cross stabiliser

Aluminium, Ø 16 mm

With LW of 1190 mm and up

20Q153ZN

Cutting for 5: LW / 2 - 147 mm

SERVO-DRIVE: LW / 2 - 165 mm

Composed of:

- 1 x connecting piece
- 1 x fixing
- 2 x cross stabiliser cover caps

6 SERVO-DRIVE set

Nylon

RAL 7037 dust grey

21FA000

Composed of:

- 1 x drive unit
- 1 x distribution cable, 1500 mm
- 1 x connecting node
- 2 x cable end protectors

We recommend one SERVO-DRIVE drive unit per set for connected fronts!

Standard
SERVO

KH	Cabinet height
LW	Inner cabinet width

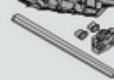



	1	Lift mechanism set KH 350-525		
		mm KH 526-675 mm KH 676-820	20S2A00.05	20S2B00.05
		mm Composed of: 2 x symmetrical lift mechanisms 10 x chipboard screws Ø 4 x 35 mm	20S2E00.05	20S2F00.05
			20S2G00.05	20S2H00.05
			20S2I00.05	
	2	Lever arm set		
		Steel, nickel plated		

		Composed of:		
	2a	1 x lever arm left		
	2b	1 x lever arm right		
	2c	2 x cross stabiliser cover caps		
	2	Lever arm set for SERVO-DRIVE		
		Steel, nickel plated		
			21S3500.01	
		Includes:		
	2a	1 x SERVO-DRIVE lever arm left		
	2b	1 x SERVO-DRIVE lever arm right		
	2c	2 x cross stabiliser cover caps		

		3 Cover cap set		
		Nylon		
		light grey, silk white		20S8000
		Composed of:		
	2a	1 x cover cap large left		
	2b	1 x cover cap large right		
	2c	2 x round cover caps		



	Bit PZ cross slot	
	Size 2, length 39 mm	
		BIT-PZ KS2
	7, 8, 9	Blum transformer, flex and transformer unit housing
		Page 74

The cabinet front and door weight is required in order to select the correct lift mechanism.

Example: KH = 600 mm, weight of front = 10 kg

Lift mechanism selection = 20S2E00.05

KH = 602 mm -> 600 mm, KH = 603 mm -> 605 mm

KH (mm)	Door weight (kg)		
	20S2G00.05	20S2H00.05	20S2I00.05
800	4.00-7.00	6.00-12.25	10.50-20.00
795	4.00-7.00	6.00-12.25	10.50-20.00
790	4.00-7.00	6.00-12.25	10.75-20.00
785	4.00-7.00	6.25-12.50	10.75-20.00
780	4.00-7.00	6.25-12.50	10.75-20.25
775	3.75-7.00	6.25-12.50	11.00-20.25
770	3.75-7.00	6.25-12.50	11.00-20.25
765	3.75-7.25	6.50-12.50	11.00-20.25
760	3.75-7.25	6.50-12.75	11.25-20.25
755	3.75-7.25	6.50-12.75	11.25-20.50
750	3.50-7.25	6.50-12.75	11.50-20.50
745	3.50-7.25	6.50-12.75	11.50-20.50
740	3.50-7.25	6.50-12.75	11.75-20.75
735	3.50-7.50	6.50-13.00	11.75-20.75
730	3.50-7.50	6.75-13.00	11.75-21.00
725	3.50-7.50	6.75-13.00	12.00-21.00
720	3.50-7.50	6.75-13.00	12.00-21.25
715	3.50-7.50	6.75-13.00	12.00-21.25
710	3.50-7.75	6.75-13.25	12.25-21.25
705	3.50-7.75	6.75-13.25	12.25-21.50
700	3.50-7.75	6.75-13.25	12.50-21.50
695	3.50-7.75	6.75-13.25	12.50-21.50
690	3.50-7.75	6.75-13.25	12.75-21.50
685	3.50-8.00	7.00-13.25	12.75-21.50
680	3.50-8.00	7.00-13.50	13.00-21.50
676	3.50-8.00	7.00-13.50	13.00-21.50

KH (mm)	Door weight (kg)		
	20S2D00.05	20S2E00.05	20S2F00.05
675	3.00-5.25	5.00-11.00	0 9.75-19.00
670	3.00-5.25	5.00-11.00	0 9.75-19.00
665	3.00-5.25	5.00-11.00	0 9.75-19.00
660	3.00-5.50	5.25-11.25	10.00-19.00
655	3.00-5.50	5.25-11.25	10.00-19.00
650	3.00-5.50	5.25-11.25	10.00-19.00
645	3.00-5.50	5.25-11.25	10.00-18.75
640	3.00-5.50	5.25-11.25	10.00-18.75
635	3.00-5.50	5.25-11.50	10.25-18.75
630	3.00-5.75	5.50-11.50	10.25-18.75
625	3.00-5.75	5.50-11.50	10.25-18.75

620	3.00-5.75	5.50-11.50	10.25-18.75
615	3.00-5.75	5.50-11.50	10.25-18.75
610	3.00-6.00	5.50-11.75	10.50-18.50
605	3.00-6.00	5.50-11.75	10.50-18.50
600	3.00-6.00	5.50-11.75	10.50-18.50
595	3.00-6.00	5.50-11.75	10.50-18.50
590	3.00-6.00	5.50-12.00	10.75-18.25
585	3.00-6.25	5.75-12.00	10.75-18.25
580	3.00-6.25	5.75-12.00	11.00-18.00
575	3.00-6.25	5.75-12.00	11.00-18.00
570	3.00-6.25	5.75-12.25	11.25-17.75
565	3.00-6.25	5.75-12.25	11.25-17.75
560	3.00-6.50	6.00-12.25	11.25-17.50
555	3.00-6.50	6.00-12.50	11.50-17.50
550	3.00-6.50	6.00-12.50	11.50-17.25
545	3.00-6.50	6.00-12.50	11.50-17.25
540	3.00-6.50	6.00-12.75	11.75-17.00
535	3.00-6.75	6.25-12.75	11.75-16.75
530	3.00-6.75	6.25-12.75	11.75-16.75
526	3.00-6.75	6.25-13.00	12.00-16.50

KH (mm)	Door weight (kg)		
	20S2A00.05	20S2B00.05	20S2C00.05
525	2.50-4.00	3.25-7.50	7.25-15.00
520	2.50-4.00	3.50-7.50	7.25-15.00
515	2.50-4.00	3.50-7.50	7.25-14.75
510	2.50-4.00	3.50-7.75	7.50-14.75
505	2.50-4.00	3.50-7.75	7.50-14.75
500	2.50-4.25	3.50-7.75	7.50-14.75
495	2.50-4.25	3.75-7.75	7.50-14.50
490	2.50-4.25	3.75-8.00	7.75-14.50
485	2.50-4.25	3.75-8.00	7.75-14.25
480	2.50-4.25	3.75-8.00	7.75-14.25
475	2.50-4.25	3.75-8.00	7.75-14.00
470	2.50-4.25	4.00-8.25	8.00-14.00
465	2.25-4.25	4.00-8.25	8.00-13.75
460	2.25-4.25	4.00-8.25	8.00-13.75
455	2.25-4.25	4.00-8.50	8.25-13.50
450	2.25-4.25	4.00-8.50	8.25-13.50
445	2.25-4.50	4.25-8.50	8.25-13.25
440	2.25-4.50	4.25-8.50	8.25-13.00
435	2.25-4.50	4.25-8.75	8.50-13.00
430	2.25-4.50	4.25-8.75	8.50-12.75
425	2.25-4.50	4.25-8.75	8.50-12.75
420	2.25-4.50	4.25-8.75	8.50-12.50
415	2.25-4.50	4.25-8.75	8.50-12.50
410	2.25-4.50	4.25-9.00	8.75-12.25
405	2.25-4.50	4.25-9.00	8.75-12.00
400	2.00-4.75	4.25-9.00	8.75-12.00
395	2.00-4.75	4.50-9.00	8.75-11.75
390	2.00-4.75	4.50-9.00	8.75-11.50
385	2.00-4.75	4.50-9.25	9.00-11.50
380	2.00-4.75	4.50-9.25	9.00-11.25
375	2.00-4.75	4.50-9.25	9.00-11.25
370	2.00-4.75	4.50-9.25	9.00-11.00
365	2.00-4.75	4.50-9.25	9.00-11.00
360	2.00-4.75	4.50-9.50	9.25-10.75
355	2.00-4.75	4.50-9.50	9.25-10.50
350	2.00-5.00	4.50-9.50	9.25-10.50

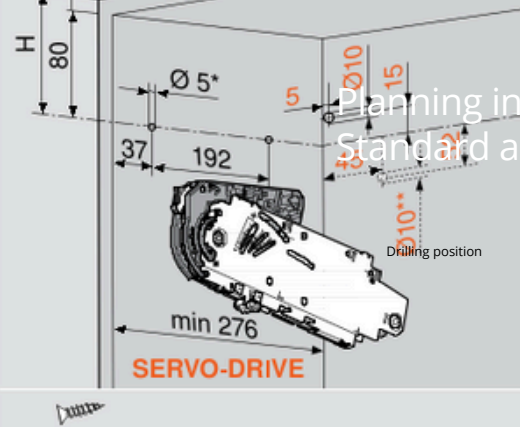

Planning information
Standard and SERVO-DRIVE for

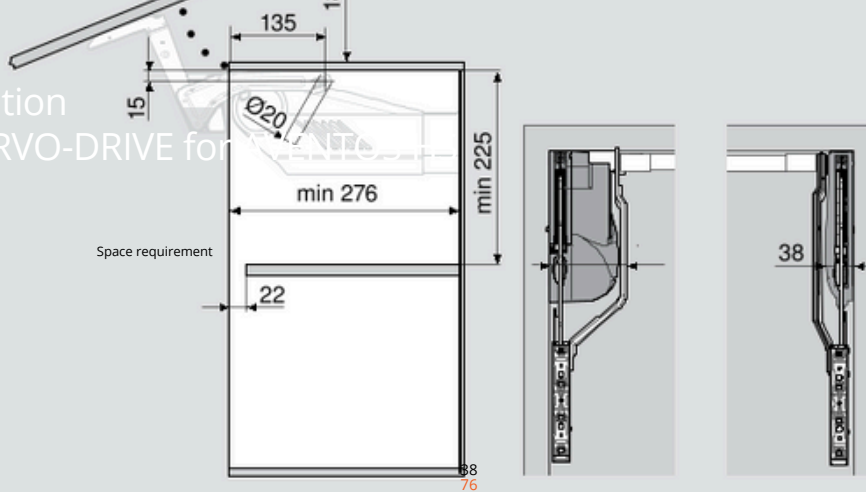

H = 80 + SOB

5 x Ø 4 x 35 mm

Drilled hole for SERVO-DRIVE distribution cable, left only

* Drilling depth 5 mm

** Alternative drilling

SOB Top panel thickness

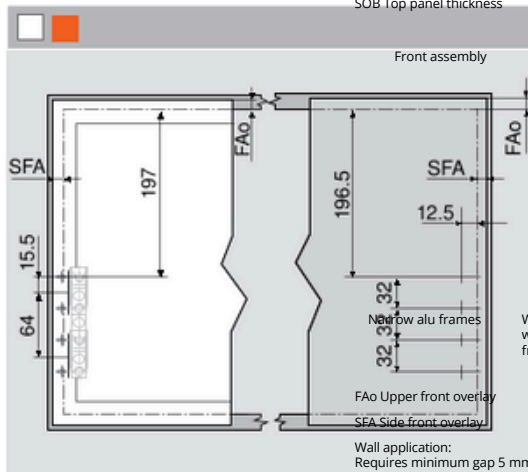

¹⁾ Use 4 chipboard screws (609.1x00) per side for wooden fronts. Use 4 countersunk self tapping screws (660.0950) per side for wide aluminium frames.

Standard
SERVO-DRIVE

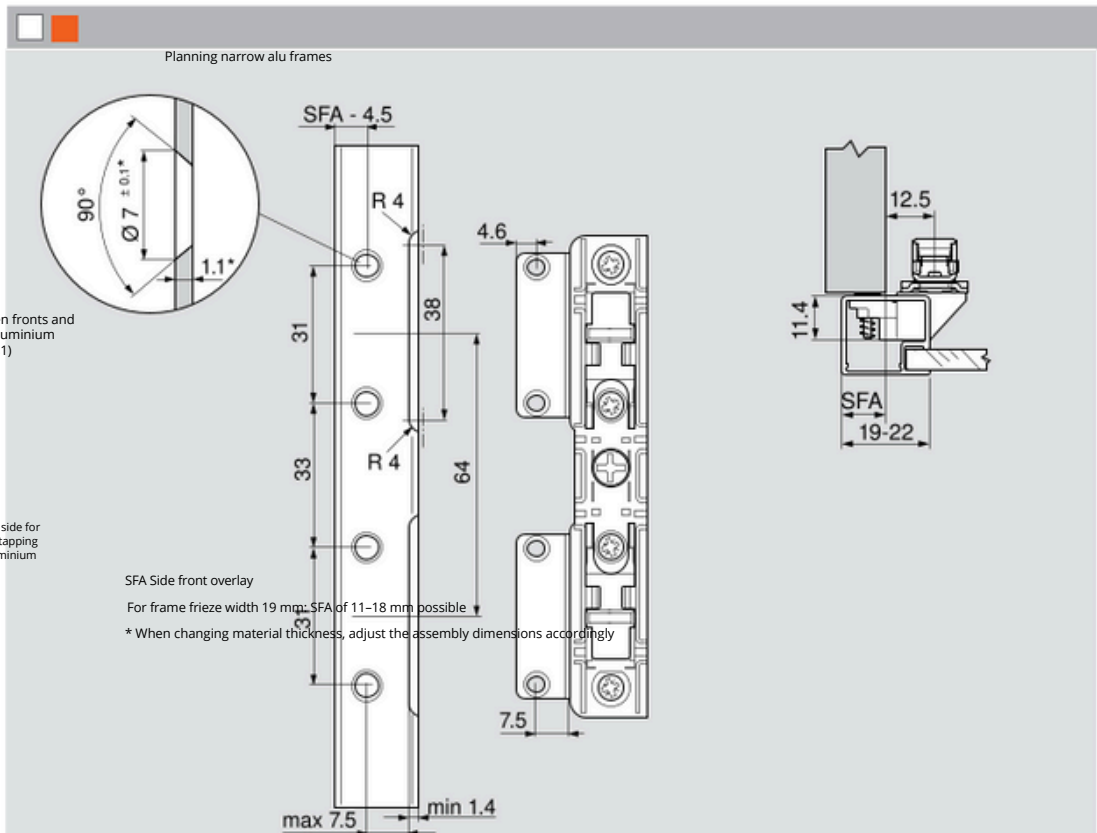

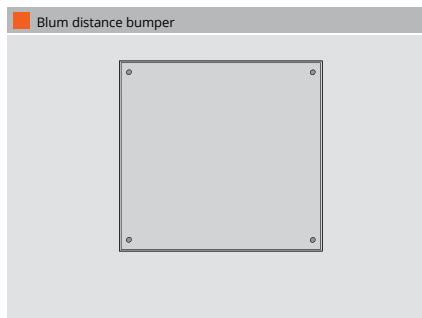
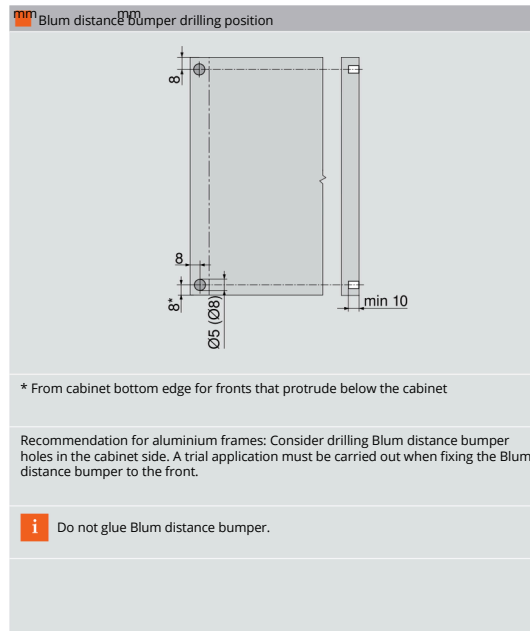
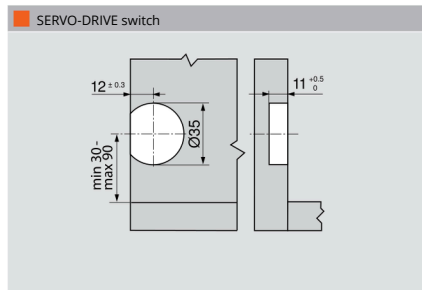
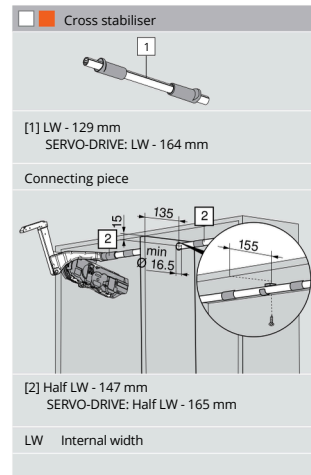
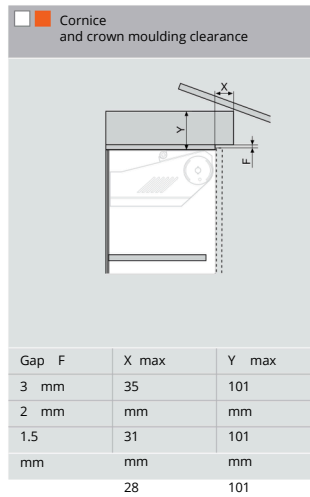
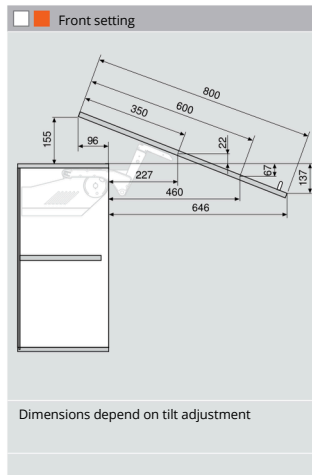



Easy **access**
combined with
visual **appeal**



Compatible with.



This product is a brilliant combination of design and function. As its name suggests, the AVENTOS HL “lift up” lifts right up and out of the user’s way so that everything is always within easy reach. As a result, even special installations are possible. For example, you can integrate electrical appliances into tall cabinets. Handle-less fronts can be opened using SERVO-DRIVE technology and without any need for hinges.



Watch video of the assembly and adjustment processes



Sheer beauty: With AVENTOS HL, electrical appliances disappear behind a continuous cabinet front.

At the heart of this fitting solution is the lift mechanism with BLUMOTION and a robust spring package.

AVENTOS HL

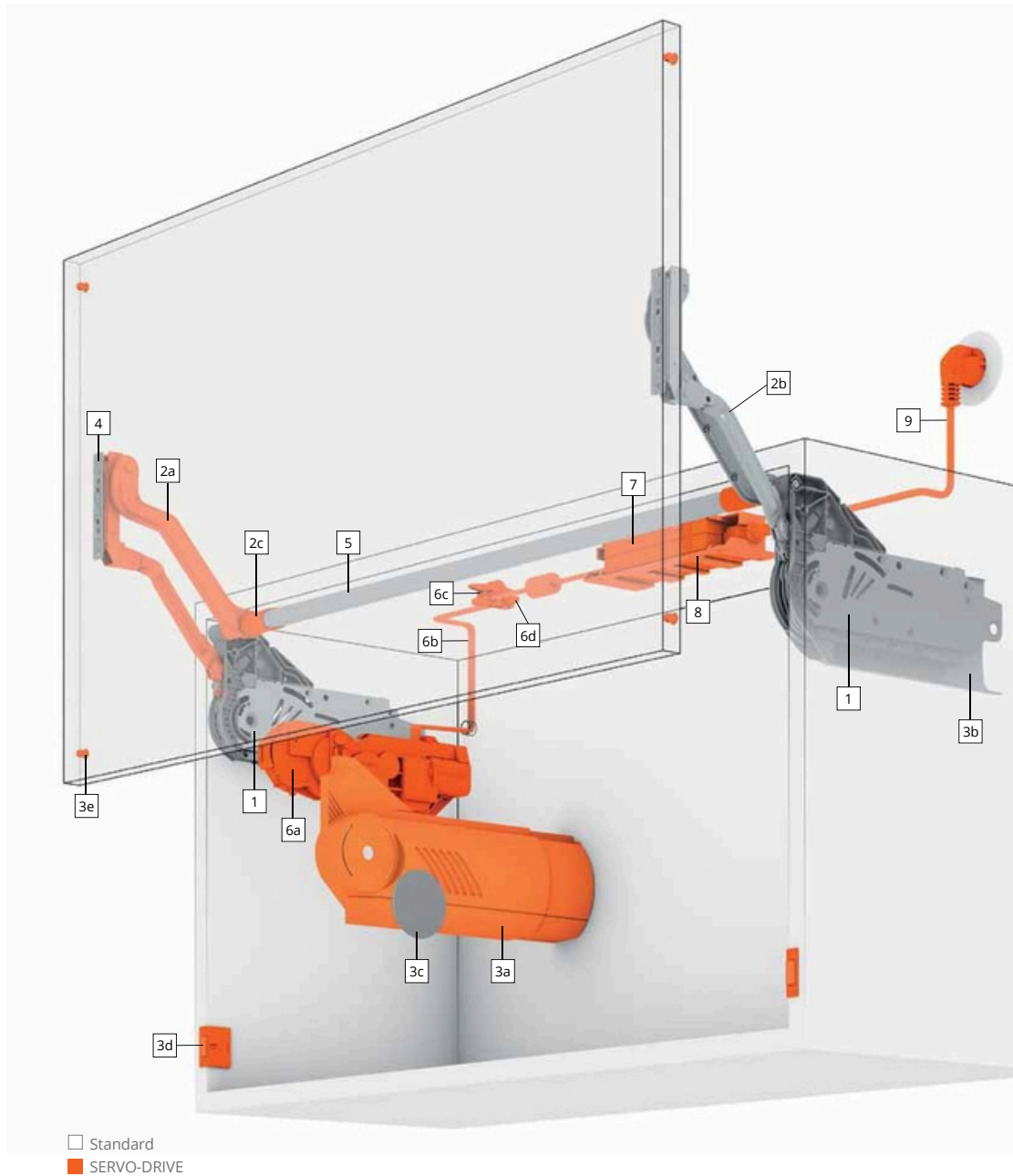



- 1** Lift mechanism
- 2a** Lever arm left
- 2b** Lever arm right
- 2c** Cross stabiliser cover cap
- 3a** Cover cap, left
The left SERVO-DRIVE cover cap is used to cover the lift mechanism, drive unit and distribution cable. To cover the cabling, the cover cap can be expanded up to an internal depth of 350 mm.
- 3b** Cover cap right
- 3c** Cover cap round
- 3d** SERVO-DRIVE switch The SERVO-DRIVE switch is attached to the cabinet side at the bottom. The switch signals the drive unit via a wireless connection. The 2.4 GHz frequency is certified for international use.
- 3e** Blum distance bumper
The Blum distance bumper creates and maintains the required trigger path of 2 mm.
- 4** Front fixing bracket
- 5** Oval cross stabiliser
- 6a** Drive unit
The drive unit is attached without tools to the left lift mechanism. The same drive unit can be used for all lift mechanisms.
- 6b** Distribution cable
This cable is used to supply power to the drive unit. The maximum permitted operating power is 24 V.
- 6c** Connecting node + cable end protector
- 6d** This node establishes the electrical connection between the distribution cable and the transformer. The cable end protector is inserted into the "open" end of the cable.
- 7** Blum transformer + flex
- 9** The Blum transformer can be used worldwide. It converts the country-specific mains voltage to 24 V direct current. You must use a flex with a regular plug for the respective country depending on the installation location.
- 8** Transformer unit housing
The transformer is easily and securely stored in the transformer unit housing.

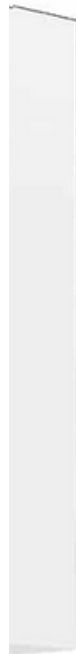

Order information Standard and SERVO-DRIVE for AVENTOS HL

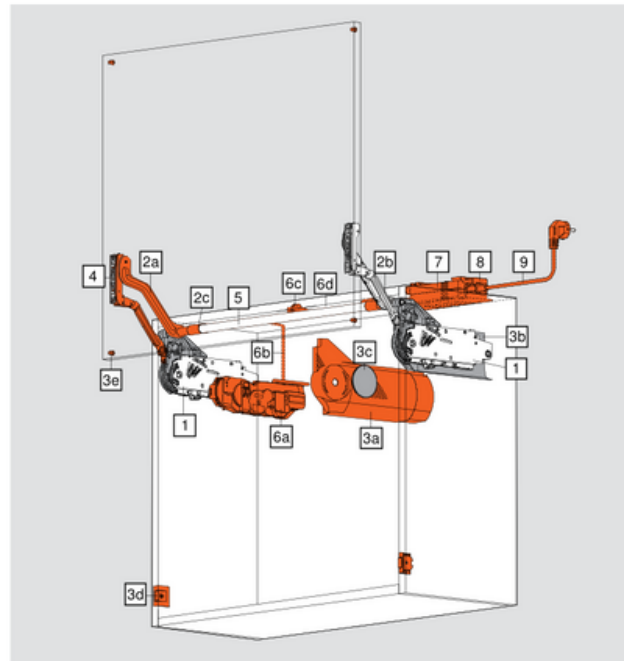

5 types of lift mechanisms are enough to cover a wide range of applications.

In order to select the correct lift mechanism, it is necessary to establish both the cabinet height and the weight of the front (including the handle).

□ Standard
■ SERVO-DRIVE

	Cabinet height			
	300-349 mm	350-399 mm	400-550 mm	450-580 mm
	Lever arm set			
	□ 20L3200.06	□ 20L3500.06	□ 20L3800.06	□ 20L3900.06
Lift mechanism set	■ 21L3200.01	■ 21L3500.01	■ 21L3800.01	■ 21L3900.01
20L2100.05	1.25-4.25 kg	1.25-2.50 kg		
20L2300.05	3.50-7.25 kg	1.75-5.00 kg	1.75-3.50 kg	
20L2500.05	6.50-12.00 kg	4.25-9.00 kg	2.75-6.75 kg	2.00-5.25 kg
20L2700.05	11.00-20.00 kg	8.00-14.75 kg	5.75-11.75 kg	4.25-9.25 kg
20L2900.05		13.50-20.00 kg	10.50-20.00 kg	8.25-16.50 kg

A trial application is recommended when you are in a borderline area of the individual lift mechanism.

□ ■ 1	Lift mechanism set	□ ■ 2	Lever arm set Cabinet height
	20L2100.05		300-349 mm Cabinet height
	20L2300.05		350-399 mm Cabinet height
	20L2500.05		400-550 mm Cabinet height
	20L2700.05		450-580 mm
	20L2900.05		
Composed of:		Composed of:	
2 x symmetrical lift mechanisms		2a	1 x lever arm left
10 x chipboard screws Ø 4 x 35 mm		2b	1 x lever arm right
		2c	2 x cross stabiliser cover caps

Planning information Standard and SERVO-DRIVE for AVANTOS HL

SERVO-DRIVE

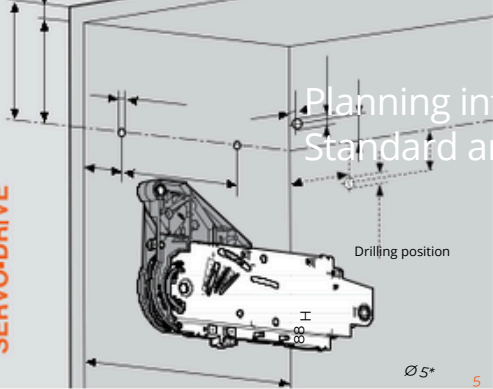

Space requirement

SERVO-DRIVE

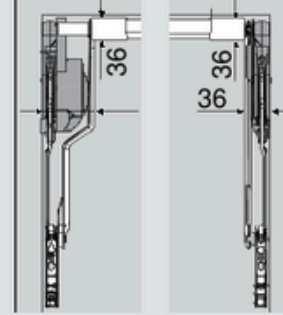

37 192

min 278

5 x Ø 4 x 35 mm

Drilled hole for SERVO-DRIVE distribution cable, left only

* Drilling depth 5 mm

** Alternative drilling

SOB Top panel thickness

15 Ø10

45 52

Ø10**

H = 88 + SOB

Lever arm set

min LH* Y* LH Internal cabinet height

m mm KH Cabinet height

20L3200.06	21L3200.01	m	264
20L3500.06	21L3500.01	262	352
20L3800.06	21L3800.01	312	440
20L3900.06	21L3900.01	362	529

* Dimensions apply to lower gap = 0 mm

412

Front assembly

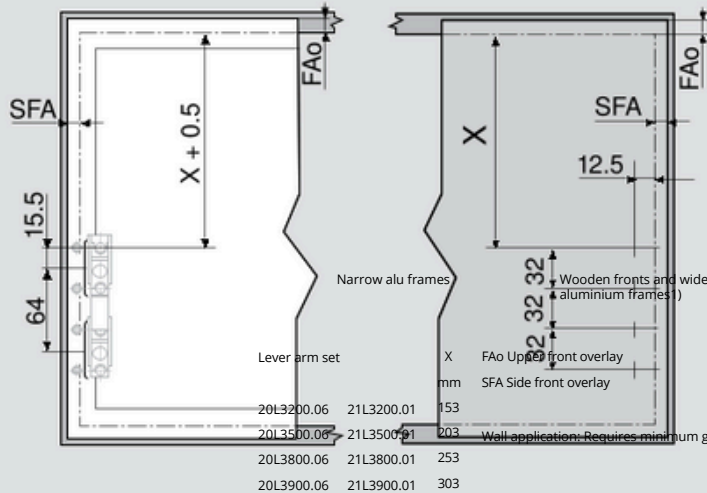

¹⁾ Use 4 chipboard screws (609.1x00) per side for wooden fronts. Use 4 countersunk self tapping screws (660.0950) per side for wide aluminium frames.

Standard
SERVO-DRIVE

Planning narrow alu frames

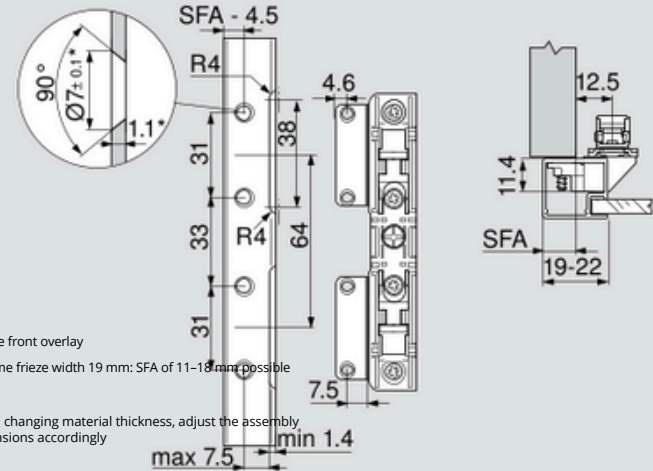

SFA Side front overlay
For frame frieze width 19 mm: SFA of 11-18 mm possible

* When changing material thickness, adjust the assembly dimensions accordingly



Front setting

Lever arm set		a	b*	Max.
		mm	mm	mm
<input type="checkbox"/>	<input checked="" type="checkbox"/>	114	257	159
20L3200.06	21L3200.01	146	345	209
20L3500.06	21L3500.01	178	433	259
20L3800.06	21L3800.01	210	522	309.5
20L3900.06	21L3900.01			

* Dimensions apply to lower gap = 0 mm

Cornice and crown moulding clearance

SOB	X
16	28
mm	mm
18	30
mm	mm
18	31
mm	mm
18	31
mm	mm
SOB Top panel thickness	mm
mm	

Cross stabiliser

[1] LW - 129 mm
SERVO-DRIVE: LW - 164 mm

Connecting piece

[2] Half LW - 147 mm
SERVO-DRIVE: Half LW - 165 mm

LW Internal width

SERVO-DRIVE switch

Blum distance bumper drilling position

* From cabinet front edge for fronts that protrude below the cabinet

Recommendation for aluminium frames: Consider drilling the Blum distance bumper holes in the cabinet side. A trial application must be carried out when fixing the Blum distance bumper to the front.

i Do not glue Blum distance bumper.

Blum distance bumper



State - of-the - ar t
stay lifts



Compatible with.

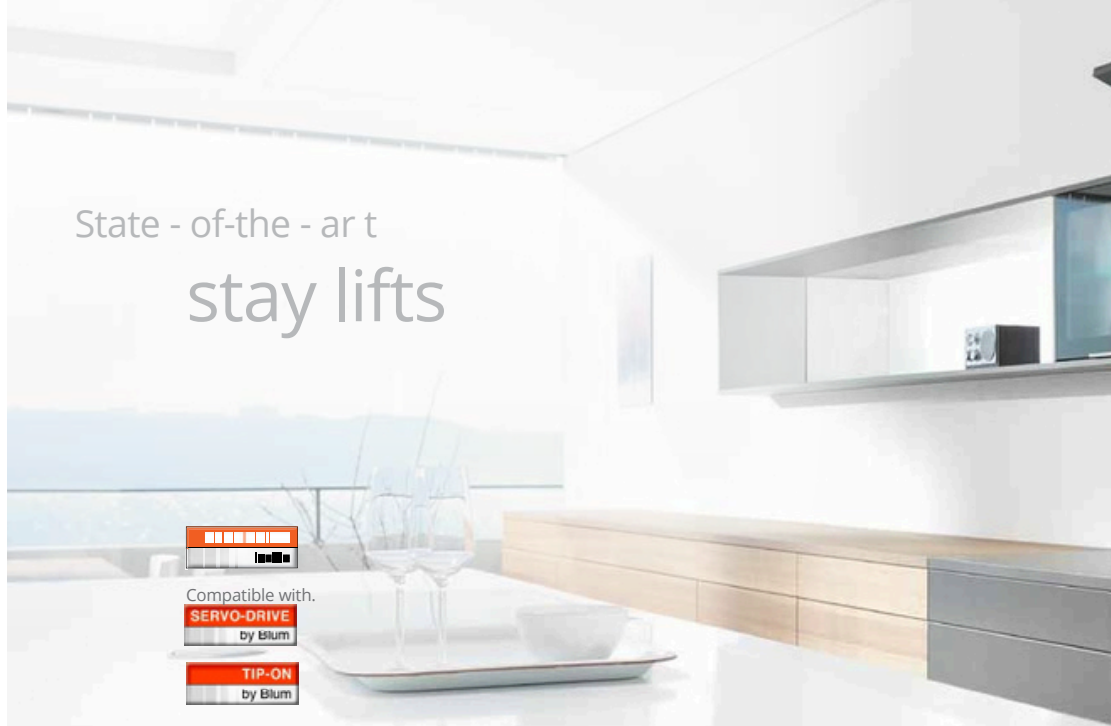

This convenient lift system fitting for mid wall units requires only a small amount of space at the top. The AVENTOS HK stay lift is another product that provides inspiration thanks to its consistently high quality of motion. Handle-less fronts can be opened using SERVO-DRIVE or TIP-ON technology and without any need for hinges.



Watch video of the assembly and adjustment processes





A single touch is all that is needed. The TIP-ON mechanical opening support system makes opening cabinets easier and more convenient than ever before.

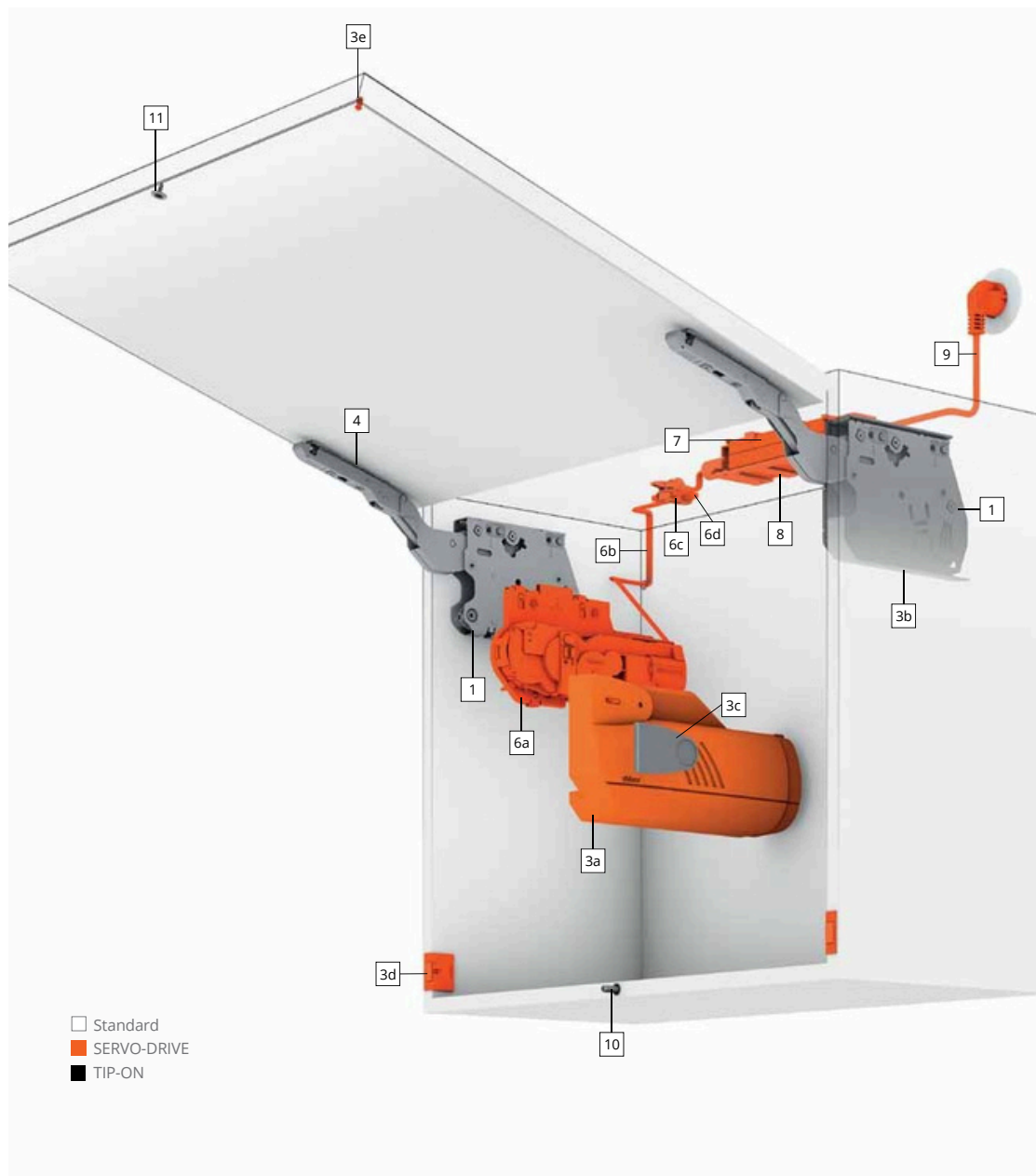

At the heart of this fitting solution is the lift mechanism with BLUMOTION and a robust spring package.



AVENTOS HK









-    **1** Lift mechanism



-    **3a** Cover cap left
The left SERVO-DRIVE cover cap is used to cover the lift mechanism, drive unit and distribution cable.
To cover the cabling, the cover cap can be expanded up to an internal depth of 350 mm.

-    **3b** Cover cap right

-    **3c** Cover cap small

-  **3d** SERVO-DRIVE switch The SERVO-DRIVE switch is attached to the cabinet side at the bottom. The switch signals the drive unit via a wireless connection. The 2.4 GHz frequency is certified for international use.

-  **3e** Blum distance bumper
The Blum distance bumper creates and maintains the required trigger path of 2 mm.

-    **4** Front fixing bracket

-  **6a** Drive unit
The drive unit is attached without tools to the left lift mechanism. A special drive unit with an adapter plate is required for AVENTOS HK.

-  **6b** Distribution cable
This cable is used to supply power to the drive unit. The max. permitted operating voltage is 24 V.

-  **6c** Connecting node +
6d cable end protector
This node establishes the electrical connection between the distribution cable and the transformer. The cable end protector is inserted into the "open" end of the cable.

-  **7** Blum transformer + flex
9 The Blum transformer can be used worldwide. It converts the country-specific mains voltage to 24 V direct current. You must use a flex with a regular plug for the respective country depending on the installation location.

-  **8** Transformer unit housing
The transformer is easily and securely stored in the transformer unit housing.

-  **10** TIP-ON

-  **11** Screw-on catch plate

Order information

Standard and SERVO-DRIVE for AVENTOS HK

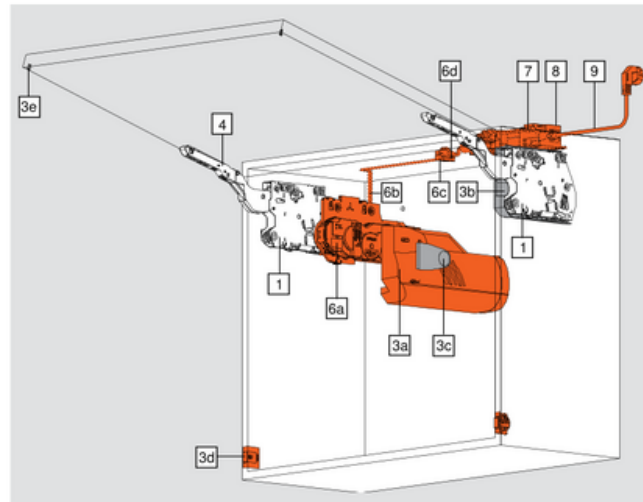

4 types of lift mechanisms are enough to cover a wide range of applications.

Using the power factor, you can calculate the number of required lift mechanisms. The power factor required depends on the weight of the front and the cabinet height.

The power factor and the door weight can be increased by 50 % when a third lift mechanism is used.

□ Standard
 ■ SERVO-DRIVE

i Power factor LF = cabinet height KH (mm) x front weight incl. double handle weight (kg)

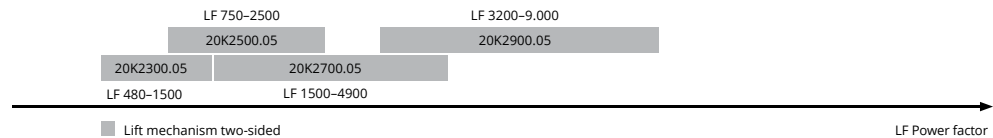

A trial application is recommended when you are in a borderline area of the individual lift mechanism.

	1 Lift mechanism set		
	Power factor	Opening angle	
	480-1500	107°	20K2300.05
	750-2500	107°	20K2500.05
	1500-4900	107°	20K2700.05
	3200-9000	100° *)	20K2900.05
Composed of:			
2 x symmetrical lift mechanisms			
6 x chipboard screws Ø 4 x 35 mm			
Max. door weight 18 kg for two lift mechanisms			
*) Pre-mounted opening angle stop			
	3 Cover cap set		
	Nylon		
	light grey, silk white	20K8000	
	Composed of:		
	3a	1 x cover cap large left	
3	1 x cover cap large right		
b	2 x cover caps small		
3c			

Note

We recommend a lift mechanism attached to the centre panel for wide cabinets. The reason for this is to prevent the middle of the front from sagging when open.



	3 Cover cap set for SERVO-DRIVE	
	Nylon	
	light grey, silk white	21K8 0 0 0
	Composed of:	
3a	1 x SERVO-DRIVE cover cap large left	
3	1 x cover cap large right	
b	2 x cover caps small	
3c	2 x SERVO-DRIVE switches	
3	4 x Blum distance bumpers, Ø 5 mm	
d		

	3e 4 Front fixing bracket set	
	Nickel plated	
	Wooden fronts and wide aluminium frames ¹⁾	20S42E1
	Narrow alu frames	20S4200A
	Composed of:	
	2 x symmetrical front fixing brackets	
	¹⁾ Use 4 chipboard screws (609.1x00) per side for wooden fronts. Use 4 countersunk self tapping screws (660.0950) per side for wide aluminium frames.	

	5 SERVO-DRIVE set	
	Nylon	
	Dust grey	21K A0 0 0
	Composed of:	
6a	1 x drive unit	
6	1 x distribution cable, 1500 mm	
b	1 x connecting node	
6c	2 x cable end protectors	
6	We recommend two synchronised drive units for a power factor > 9000.	
d		

	Opening angle stop	
	Nylon 100°Dark	
	grey 75°Dust grey	2 x 20K7041
		2 x 2 0 0 K

	Bit PZ cross slot	
	Size 2, length 39 mm	
		BIT-PZ KS2

7, 8, 9	Blum transformer, flex and transformer unit housing	
		Page 74

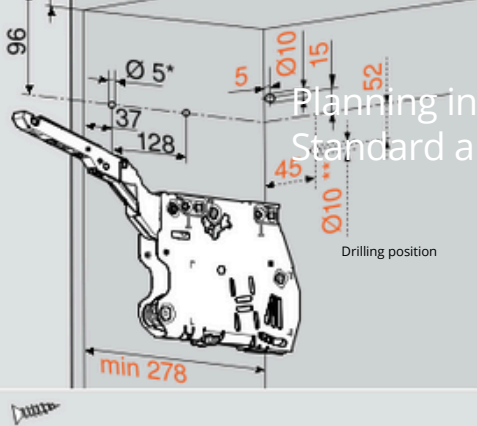

Planning information
Standard and SERVO-DRIVE OS HK

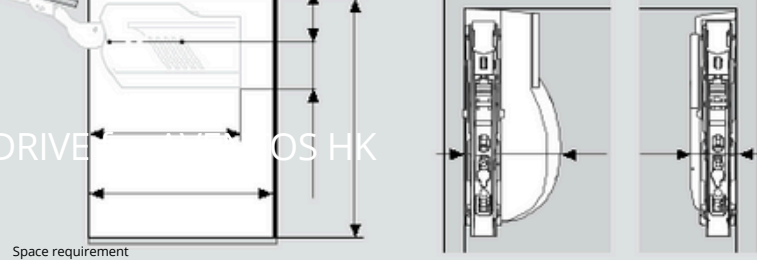

SERVO - DRIVE

min 261

- 3 x Ø 4 x 35 mm
- Drilled hole for SERVO-DRIVE distribution cable, left only
- * Drilling depth 5 mm
- ** Alternative drilling
- SOB Top panel thickness

- LH Internal cabinet height
- * Min. 261 mm with visible wall hanging bracket

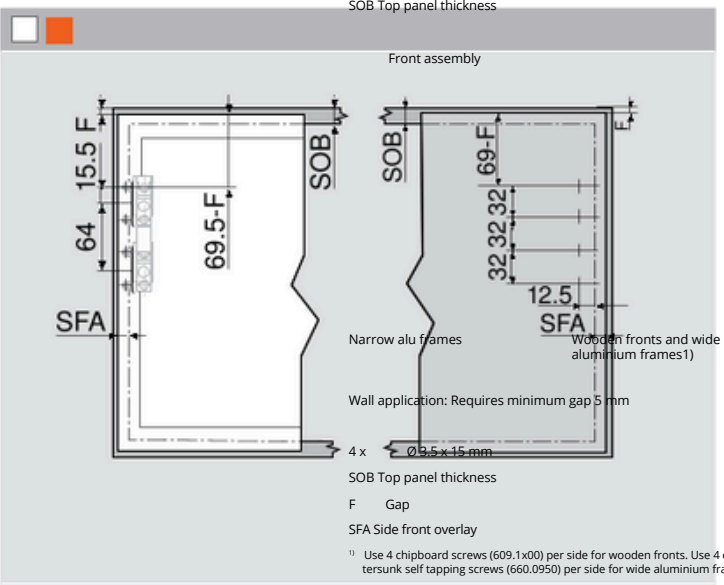

- Narrow alu frames
- Wooden fronts and wide aluminium frames1)
- Wall application: Requires minimum gap 5 mm
- 4 x Ø 3.5 x 15 mm
- SOB Top panel thickness
- F Gap
- SFA Side front overlay
- 1) Use 4 chipboard screws (609.1x00) per side for wooden fronts. Use 4 countersunk self tapping screws (660.0950) per side for wide aluminium frames.

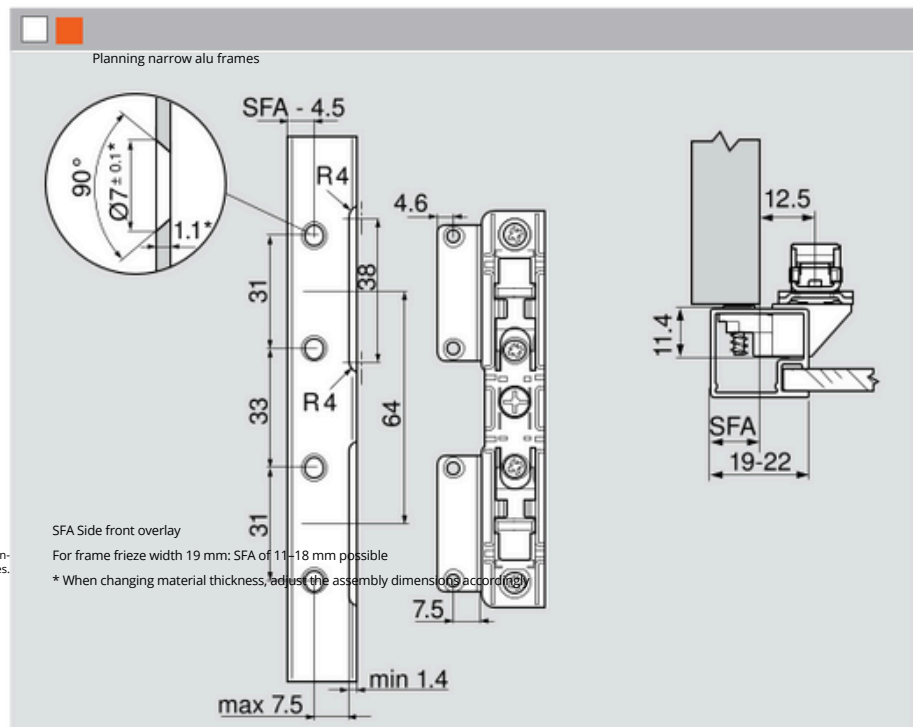

- SFA Side front overlay
- For frame frieze width 19 mm: SFA of 11-18 mm possible
- * When changing material thickness, adjust the assembly dimensions accordingly

Standard
SERVO-DRIVE



Cornice and crown moulding clearance

D (mm)	16	19	2	26	28
X (mm)	70	59	2	35	26
			4		
Opening angle stop			9		
Without 100° 75°	$Y = FH \times 0.29 - 15 + D$				
	$Y = FH \times 0.17 - 15 + D$				
	$A = FH \times 0.26 + 15 - D$				

Minimum gap

MF Minimum gap for opening (2 mm)

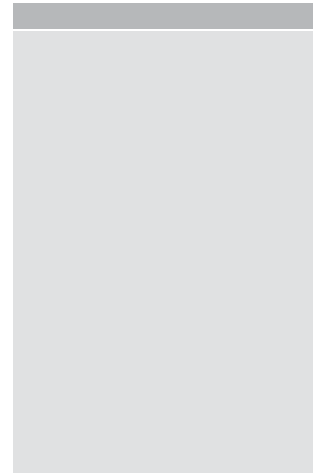

SERVO-DRIVE switch

Blum distance bumper drilling position

Blum distance bumper

In general, we recommend installing 4 distance bumpers near to the switch. For certain applications (high fronts, low weight), 2 distance bumpers may sometimes be sufficient. A trial application is recommended.

Recommendation for aluminium frames: Consider drilling the Blum distance bumper holes in the cabinet side. A trial application must be carried out when fixing the Blum distance bumper to the front.

i Do not glue Blum distance bumper.

Order information TIP-ON for AVENTOS HK

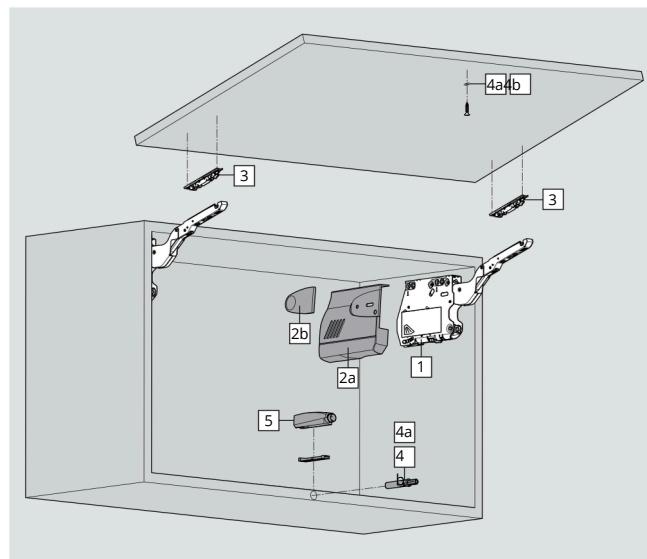

4 types of lift mechanisms are enough to cover a wide range of applications.

Using the power factor, you can calculate the number of required lift mechanisms. The power factor required depends on the weight of the front and the cabinet height.

The power factor and the door weight can be increased by 50 % when a third lift mechanism is used.

■ TIP-ON





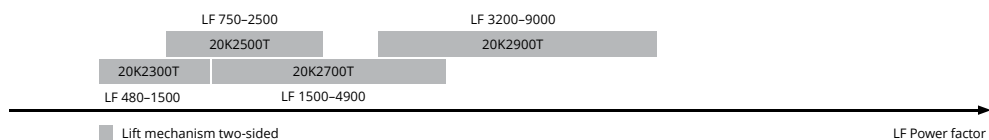

Power factor LF = cabinet height KH (mm) x front weight



A trial application is recommended when you are in a borderline area of the individual lift mechanism.

	1	Lift mechanism set	
	Power factor	Opening angle	
	480-1500	107°	20K2300T
	750-2500	107°	20K2500T
	1500-4900	107°	20K2700T
	3200-9000	100° *)	20K2900T
Composed of:			
2 x symmetrical lift mechanisms			
6 x chipboard screws Ø 4 x 35 mm			
Max. door weight 18 kg for two lift mechanisms			
*) Pre-mounted opening angle stop			
	2	Cover cap set	
	Nylon		
	light grey, silk white		20K8000
	Composed of:		
2a	1 x cover cap large left		
2b	1 x cover cap large right		
2c	2 x cover caps small		
	Opening angle stop		
	Nylon 100° 75°		
	Dark grey	2 x	20K7041
	Dust grey	2 x	2 0 K



	<p>3 Front fixing bracket set</p> <table border="1"> <tr> <td>Nickel plated</td> <td></td> </tr> <tr> <td>Wooden fronts and wide aluminium frames¹⁾</td> <td>20S42E1</td> </tr> <tr> <td>Narrow alu frames</td> <td>20S4200A</td> </tr> </table> <p>Includes:</p> <p>2 x symmetrical front fixing brackets</p> <p>¹⁾ Use 4 chipboard screws (609.1x00) for wooden fronts. Use 4 countersunk self tapping screws (660.0950) for wide alu frames.</p>	Nickel plated		Wooden fronts and wide aluminium frames ¹⁾	20S42E1	Narrow alu frames	20S4200A
Nickel plated							
Wooden fronts and wide aluminium frames ¹⁾	20S42E1						
Narrow alu frames	20S4200A						
	<p>4b TIP-ON long version set</p> <p>For front heights over 500 mm</p> <p>For drilling Ø 10 x 76 mm</p> <p>RAL 7037 nylon, dust grey</p> <p>With magnet</p> <p>Output path approx. 38 mm</p> <p>Composed of:</p> <p>1 x TIP-ON</p> <p>1 x screw-on catch plate³⁾</p> <p>1 x chipboard screw 609.1500</p> <p>³⁾ Note: The glue-on catch plate should not be used in combination with TIP-ON for AVENTOS HK</p>						
	<p>4a TIP-ON set</p> <p>For fronts up to a height of 500 mm</p> <p>For drilling Ø 10 x 50 mm</p> <p>RAL 7037 nylon, dust grey</p> <p>With magnet</p> <p>Output path approx. 18 mm</p> <p>Composed of:</p> <p>1 x TIP-ON</p> <p>1 x screw-on catch plate²⁾</p> <p>1 x chipboard screw 609.1500</p> <p>²⁾ Note: The glue-on catch plate should not be used in combination with TIP-ON for AVENTOS HK</p>						
	<p>5 Adapter plate</p> <p>Cruciform adapter plate</p> <p>Nylon 7036 platinum grey</p> <table border="1"> <tr> <td>Screws</td> <td>955.1501</td> </tr> <tr> <td>EXPANDO</td> <td>955.15E1</td> </tr> </table> <p>Assembly with Ø 3.5 mm or Ø 4 mm chipboard screws</p>	Screws	955.1501	EXPANDO	955.15E1		
Screws	955.1501						
EXPANDO	955.15E1						
	<p>Bit PZ cross slot</p> <p>Size 2, length 39 mm</p> <p>BIT-PZ KS2</p>						

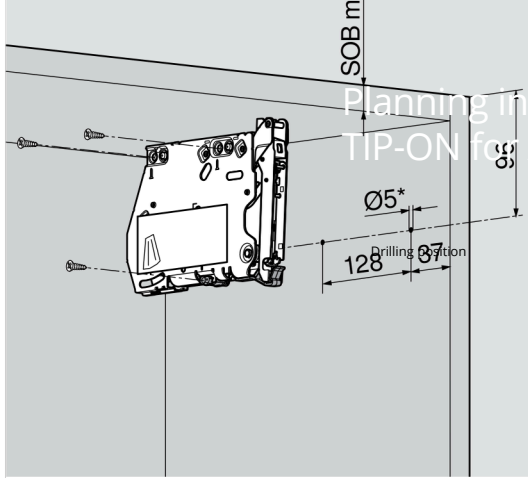

Planning information
TIP-ON for ALVENTOS HK

* Drilling depth 5 mm
SOB Top panel thickness
3x Ø 4 x 35 mm

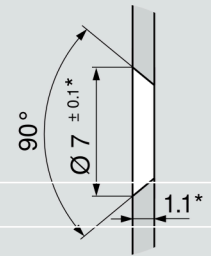
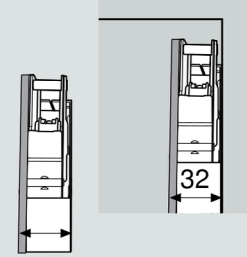
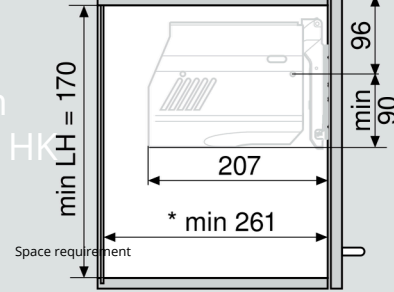

* Min. 261 mm with visible wall hanging bracket

Front assembly

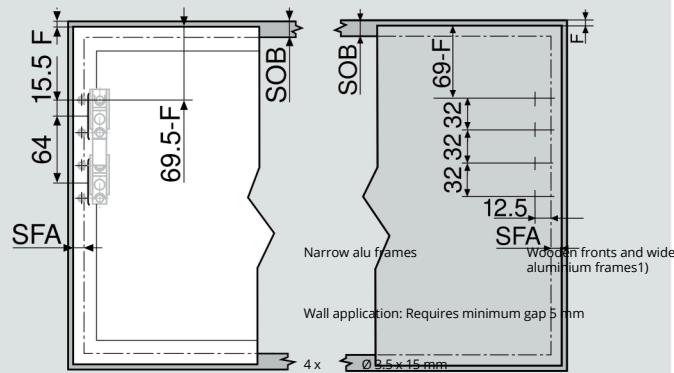

Narrow alu frames
Wooden fronts and wide aluminium frames¹⁾
Wall application: Requires minimum gap 5 mm
4 x Ø 2.5 x 15 mm
SOB Top panel thickness
F Gap
SFA Side front overlay
¹⁾ Use 4 chipboard screws (609.1x00) per side for wooden fronts.
Use 4 countersunk self tapping screws (660.0950) per side for wide aluminium frames.

TIP-ON

Planning narrow alu frames

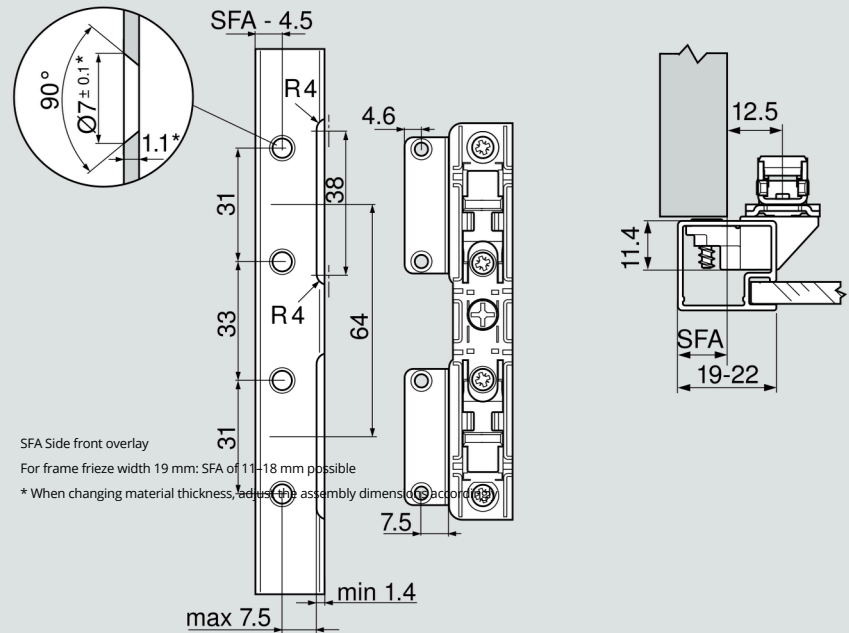

SFA Side front overlay
For frame frieze width 19 mm: SFA of 11-18 mm possible
* When changing material thickness, adjust the assembly dimensions accordingly



Cornice and crown moulding clearance

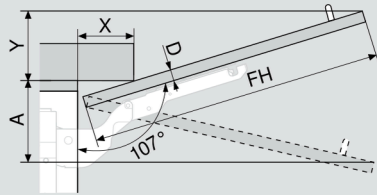

D (mm)	16	19	2	26	28
X (mm)	70	59	2	35	26
			4		
Opening angle stop			9		
Without 100° 75°	$Y = FH \times 0.29 - 15 + D$				
	$Y = FH \times 0.17 - 15 + D$				
	$A = FH \times 0.26 + 15 - D$				

Minimum gap

MF Minimum gap for opening (2 mm)

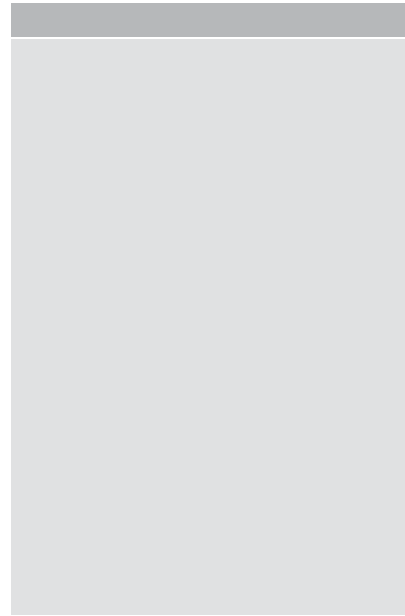

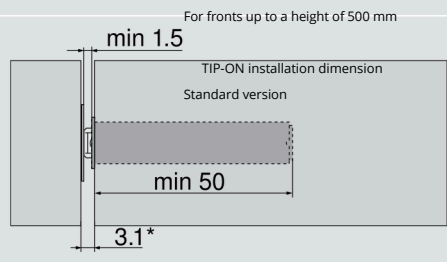
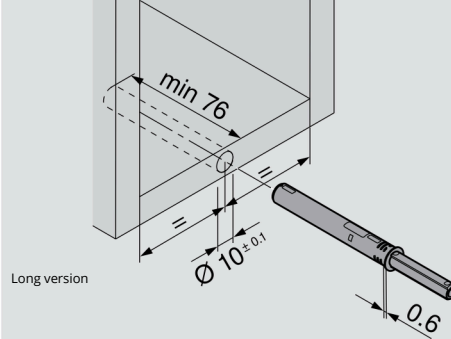
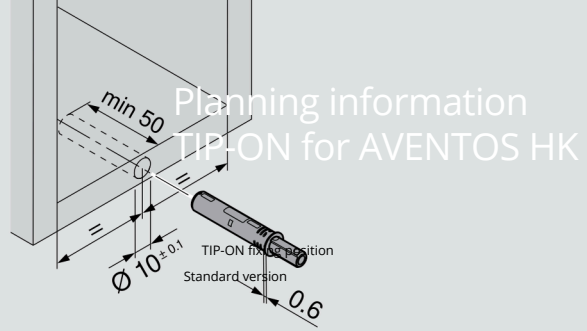

* Min. 3.1 mm with screw-on catch plate

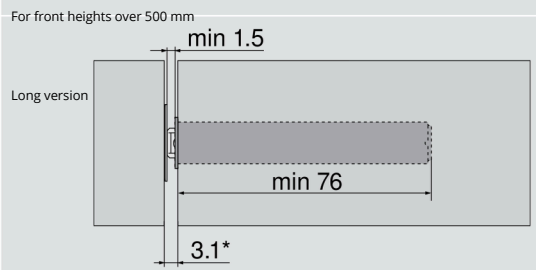

Adapter plate fixing position
Cruciform adapter plate

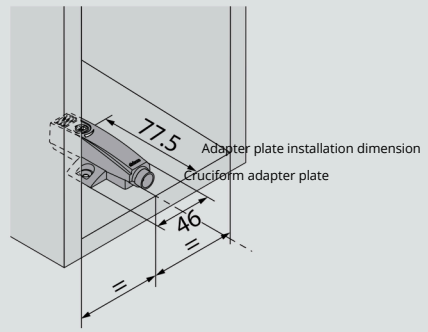

* Factory setting = 2 mm



■ Screw-on catch plate planning

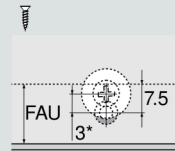
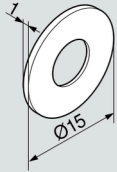

For drilling

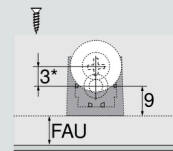

Inline adapter plate

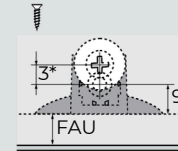

Cruciform adapter plate

* We recommend offsetting the positioning of TIP-ON by 3 mm for the screw-on catch plate.

Comment: The glue-on catch plate should not be used in combination with TIP-ON for AVENTOS HK

FAU Lower front overlay

■ TIP-ON

AVENTOS HK-S

Small lift system
but supreme
ease of motion



AVENTOS HK-S is the perfect choice for small lift systems in tall cabinets, e.g. above refrigerators. Thanks to its neat and tidy dimensions, the fitting can be perfectly integrated into small pieces of furniture, making the best possible use of the storage space.



Watch video of the assembly and adjustment processes



At the heart of this fitting solution is the lift mechanism with BLUMOTION and a robust spring package.

AVENTOS HK-S

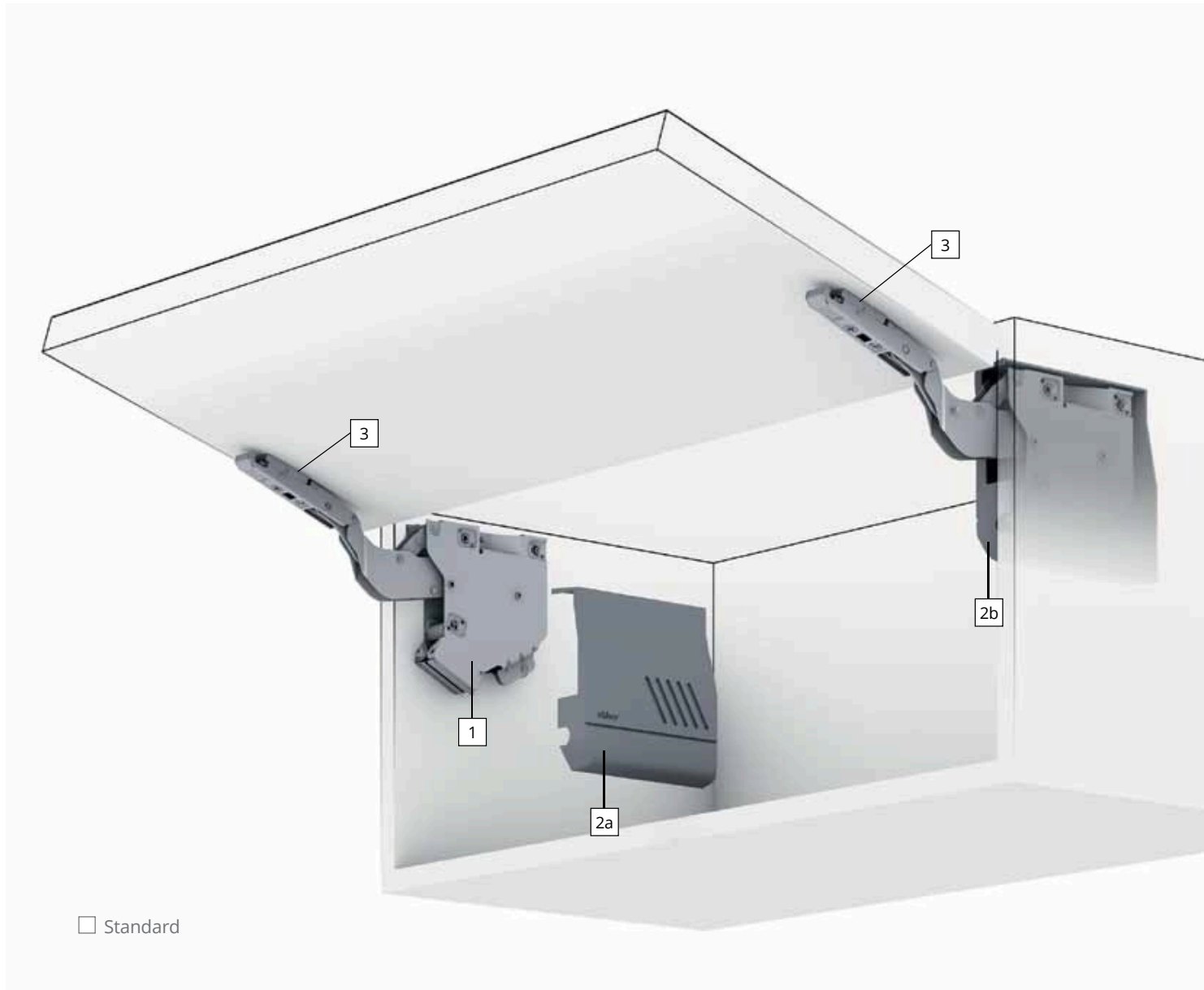



- 1** Lift mechanism
- 2a** Cover cap, left
- 2b** Cover cap right
- 3** Front fixing bracket

Order information Standard AVENTOS HK-S

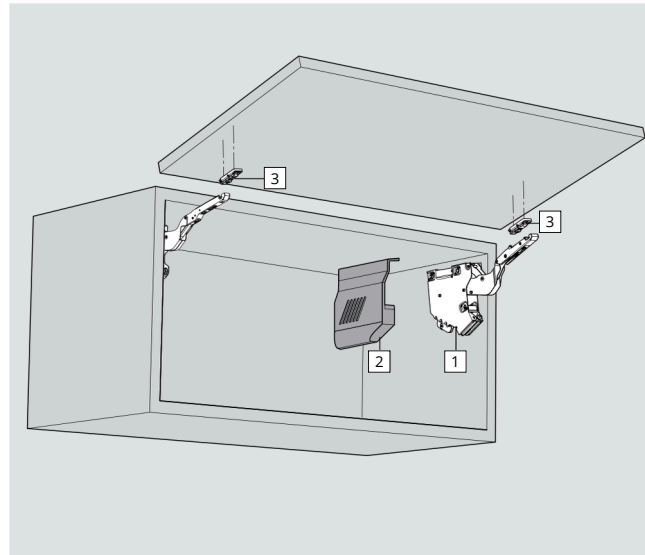

3 types of lift mechanisms are enough to cover a wide range of applications.

Using the power factor, you can calculate the number of required lift mechanisms. The power factor required depends on the weight of the front and the cabinet height. The power factor and the door weight can be increased by 50 % when a third lift mechanism is used.

The maximum cabinet height for AVENTOS HK-S is 400 mm.

Standard



Power factor LF = cabinet height KH (mm) x front weight incl. double handle weight (kg)

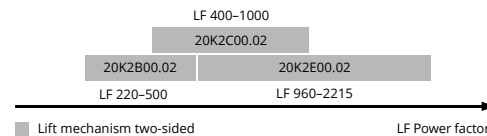



<input type="checkbox"/>	1	Lift mechanism set	
		Power factor	Spring
		200-500	Weak
			20K2B00.02
		400-1000	Medium
			20K2C00.02
		960-2215	Strong
			20K2E00.02
		Opening angle	107°
		Composed of:	
			2 x symmetrical lift mechanisms
			2 x cover caps large left/right light grey, silk white
			6 x chipboard screws, Ø 4 x 35 mm

<input type="checkbox"/>	3	Front fixing bracket	
		Wooden fronts and wide aluminium frames ¹⁾	2 x
			20K42E1.01
		¹⁾ Use 2 chipboard screws (609.1x00) for wooden fronts. Use 2 countersunk self tapping screws (660.0950) for wide alu frames.	

<input type="checkbox"/>	3	Front fixing bracket set	
		Narrow alu frames	20K4A00A01
		Composed of:	
			2 x symmetrical front fixing brackets



<input type="checkbox"/>	Opening angle stop
	Nylon 100° 75°
	Dark grey 2 x 20K7A41
	Dust grey 2 x 2.0 K 7A11

<input type="checkbox"/>	Bit PZ cross slot
	Size 2, length 39 mm
	BIT-PZ KS2

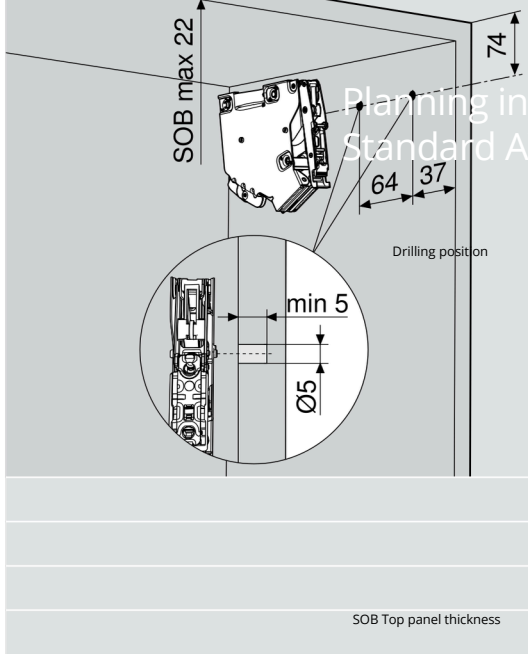

Planning information
Standard A... NTO

SOB Top panel thickness

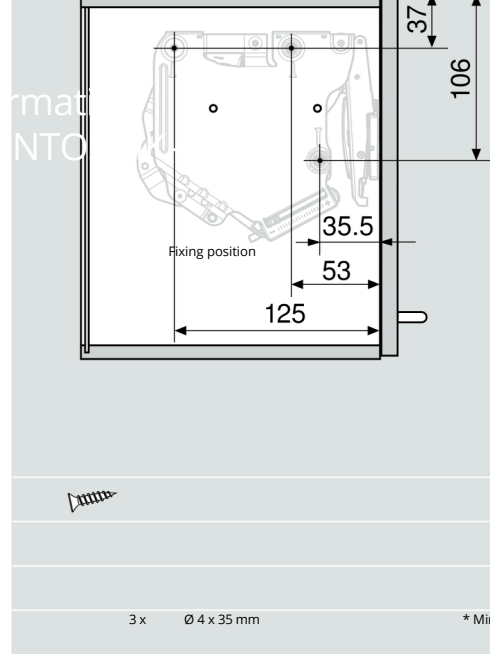

3 x Ø 4 x 35 mm

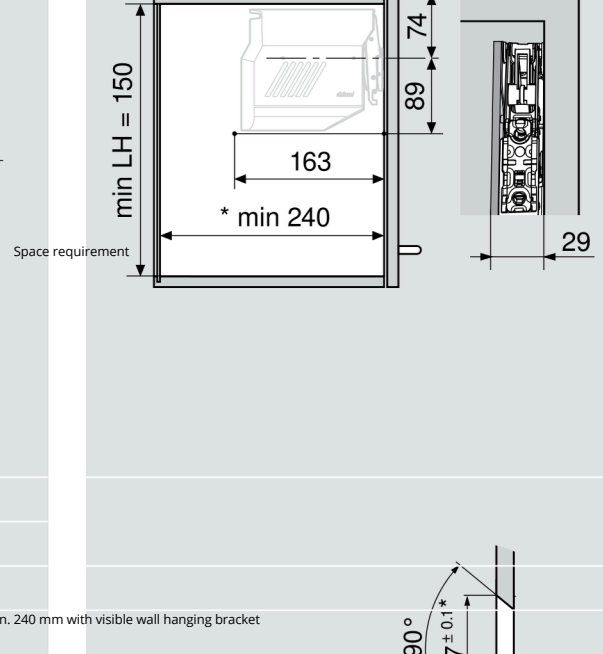

* Min. 240 mm with visible wall hanging bracket

Maximum cabinet height 400 mm

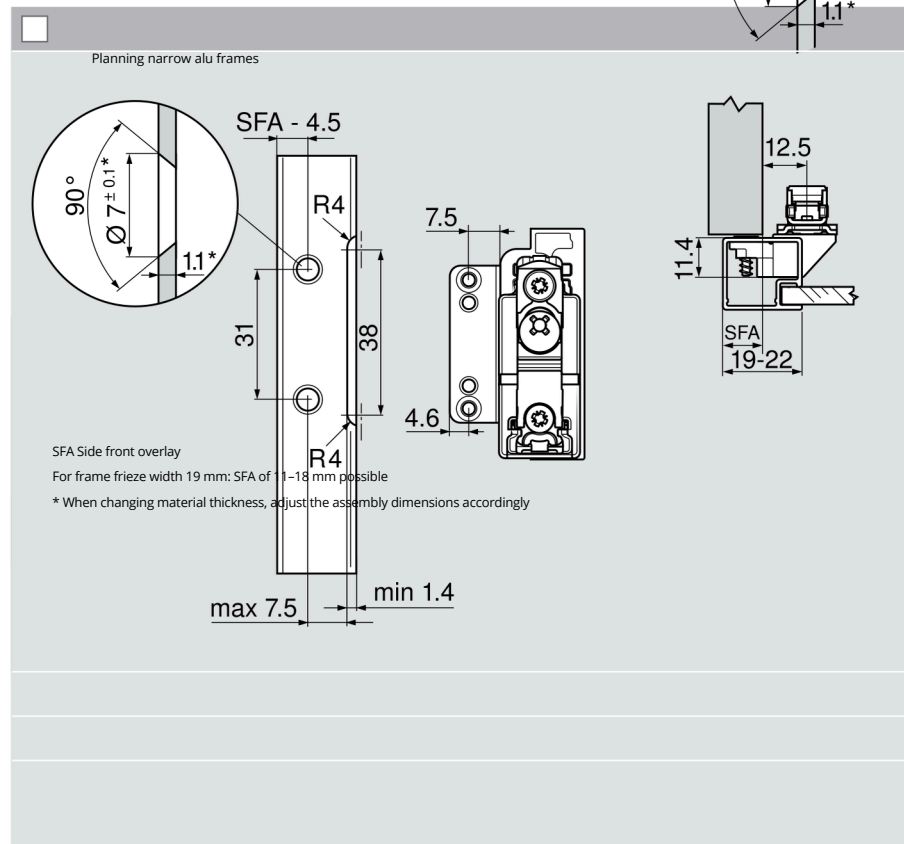
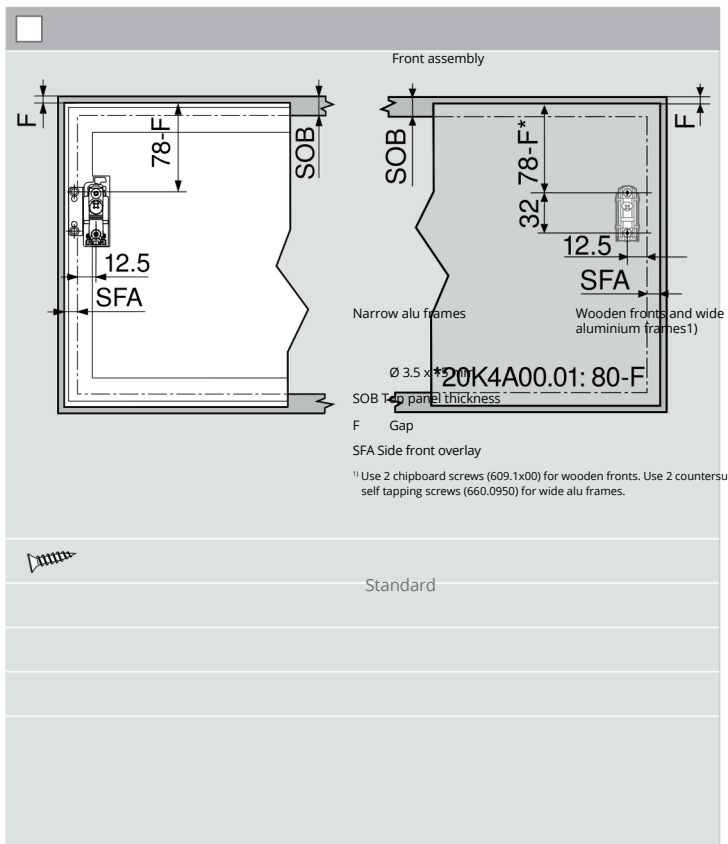
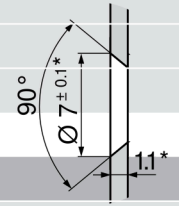



Cornice and crown moulding clearance

D (mm)	16	19	2	26
X (mm)	70	59	2	35
			4	
Opening angle stop			9	
Without 100° 75°	$Y = FH \times 0.29 - 15 + D$			
	$Y = FH \times 0.17 - 15 + D$			
	$A = FH \times 0.26 + 15 - D$			





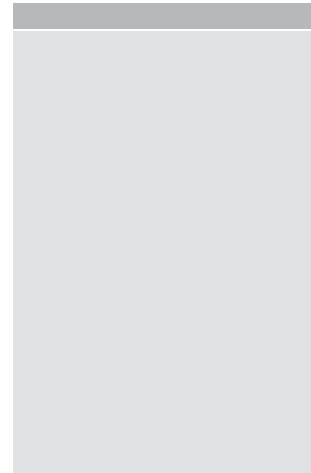

Minimum gap

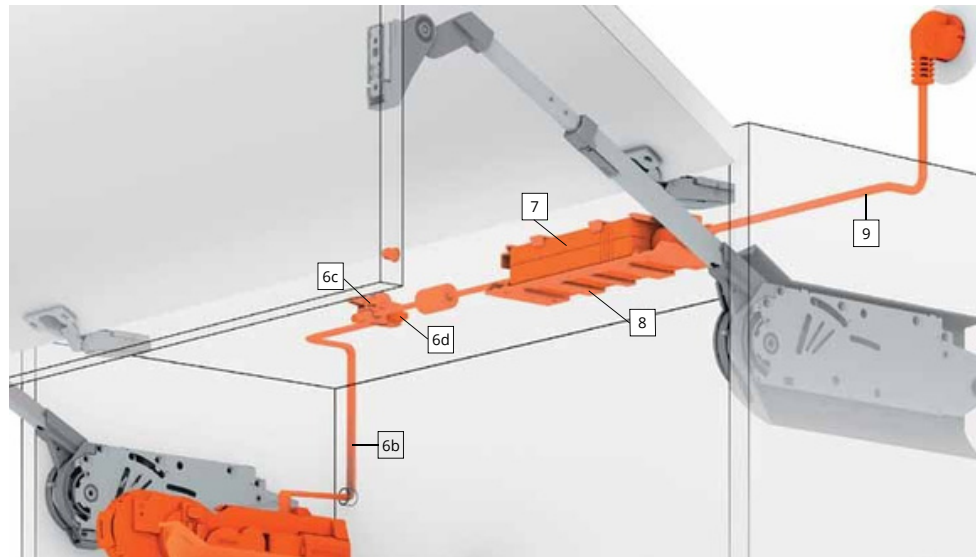
MF Minimum gap for opening (2 mm)



Order information Blum transformer and accessories



	<p>6c, 6d Connecting node + cable end protector</p> <p>Black</p> <p>Z10 V10 0 E. 0</p>		<p>9 Flex</p> <p>Flex AU</p> <p>Z10M200K</p>
	<p>6b, 6d Distribution cable for cutting to size + cable end protector</p> <p>Electrical cable length 8 m with 5 pieces cable end protector</p> <p>Z10K800AE</p> <p>Can be used as a distribution cable</p>		<p>Cable holder</p> <p>Using the cable holder, the distribution cable can be easily managed to keep everything tidy and safe.</p> <p>White</p> <p>Z10K0009</p>
	<p>7 Blum transformer</p> <p>72 W</p> <p>Language packages - installation instructions and instruction leaflet</p> <p>D EN, ES, FR, IT, PT</p> <p>Z10NE020D</p> <p><small>*Note: Blum transformer power consumption on standby is approximately 3.36kWh/a Blum drive unit power consumption on standby is approximately 2.6kWh/a</small></p>		
	<p>8 Transformer unit housing for panel fixing</p> <p>White grey</p> <p>Z10 N G12 0</p>		

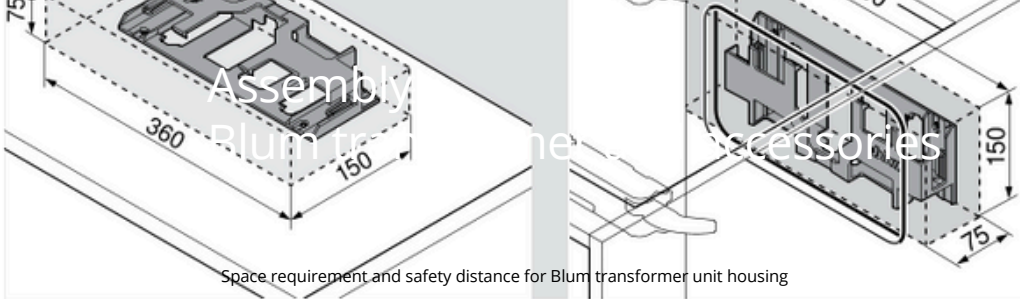

Space requirement and safety distance for Blum transformer unit housing

A safety distance of 30 mm must be maintained for air circulation (see graphic); otherwise, there is a risk that the Blum transformer could overheat.

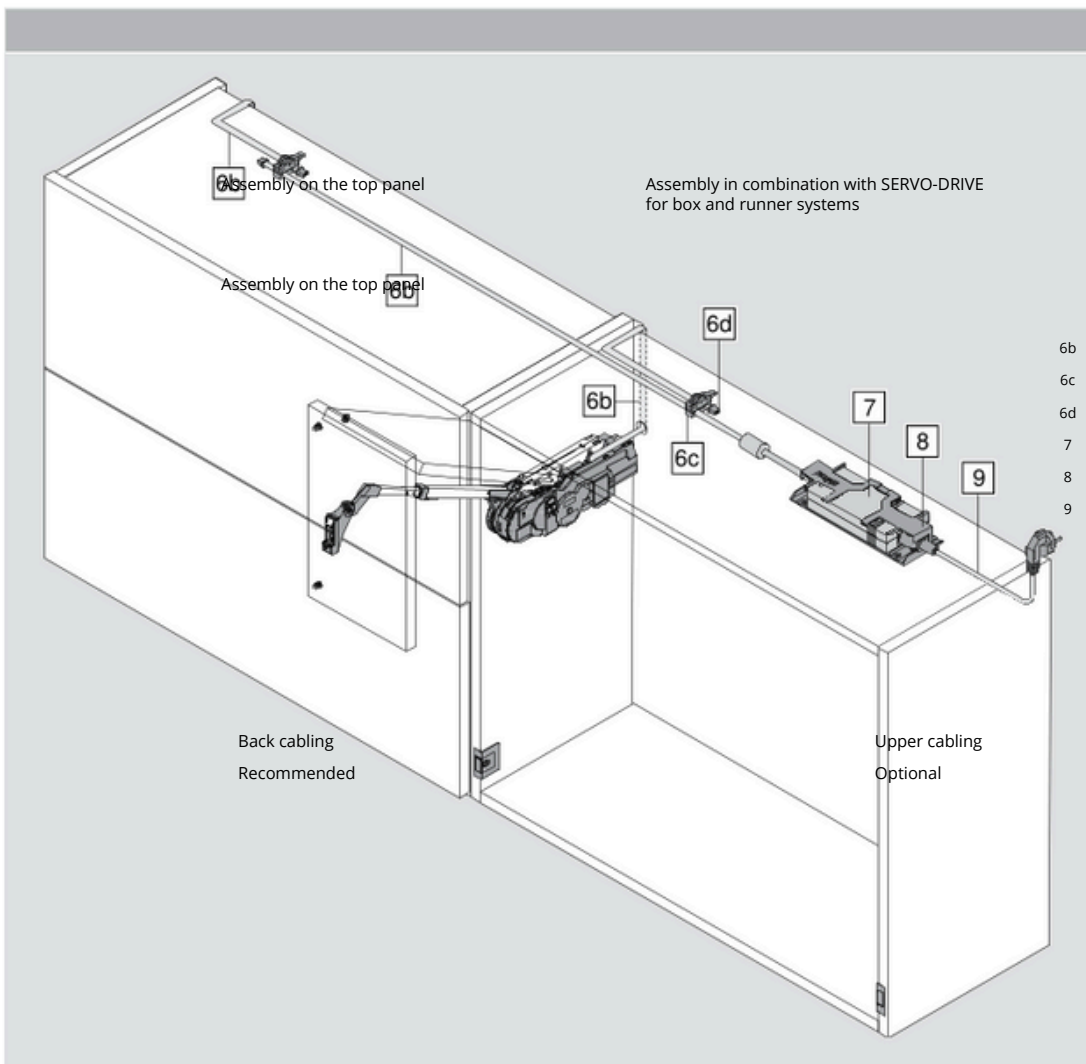

- 6b Distribution cable for cutting to size
- 6c Connecting node
- 6d Cable end protector
- 7 Blum transformer
- 8 Transformer unit housing
- 9 Flex

Only one Blum transformer can be connected to each distribution cable.

Cabinet front edge to centre of drilled hole

- HF: 167 mm
- HS: 69 or 167 mm
- HL: 74.5 or 167 mm
- HK: 167 mm



Assembly Blum transformer and accessories

Cable diameter: two cables

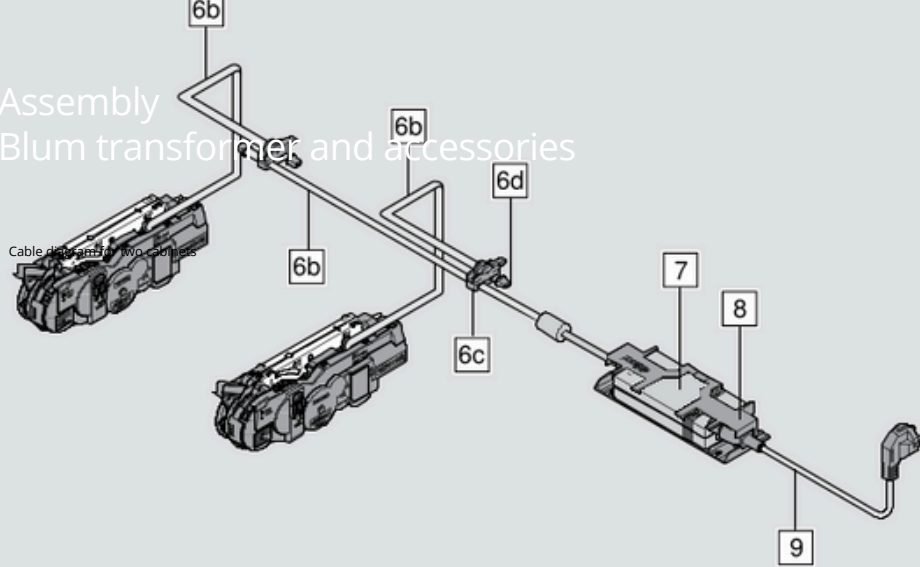

Transformer unit housing

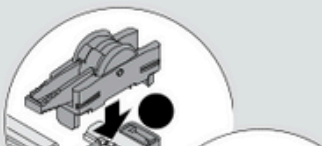
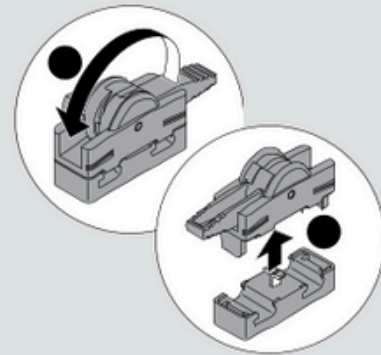
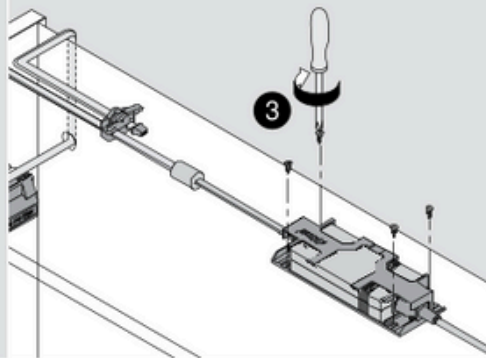
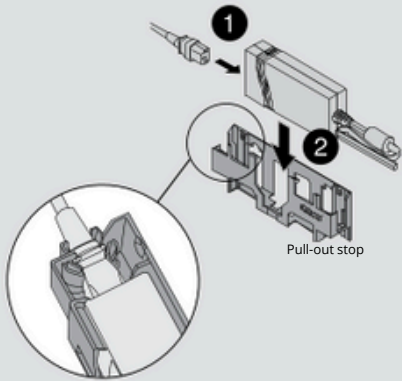

Do not damage piercing pins.

Assembly in combination with SERVO-DRIVE for box and runner systems

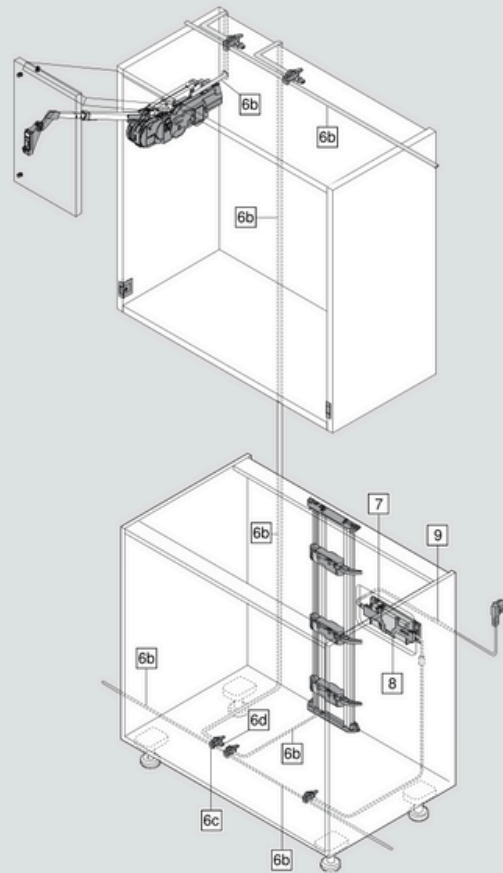

- 6b Distribution cable for cutting to size
- 6c Connecting node
- 6d Cable end protector
- 7 Blum transformer
- 8 Transformer unit housing
- 9 Flex

i Only one Blum transformer can be connected to each distribution cable.

Overview of functions SERVO-DRIVE for AVENTOS

Start-up

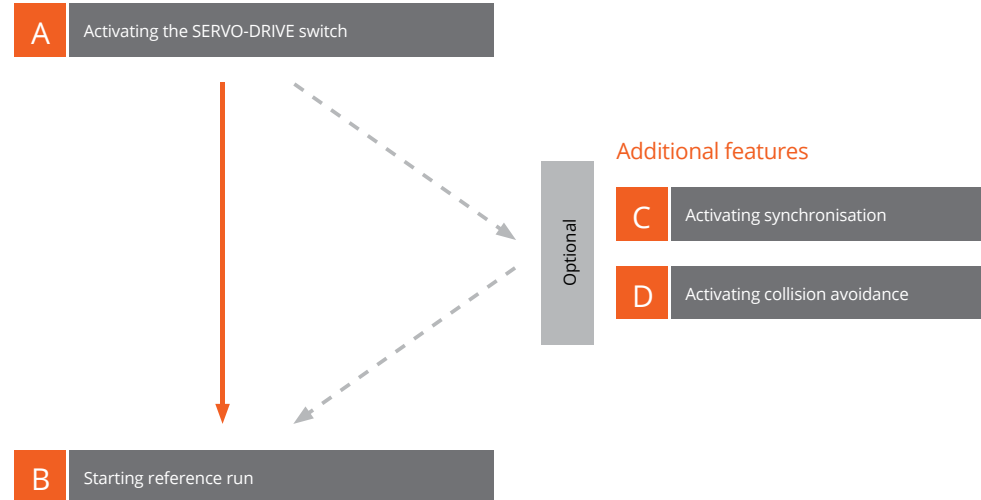

Deactivation

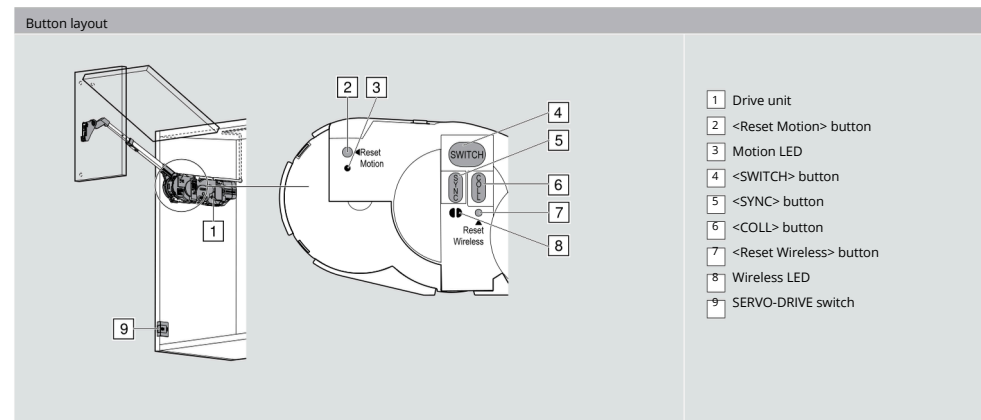
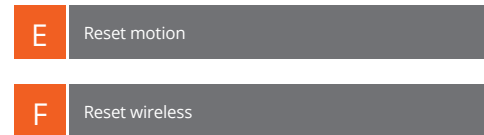

Start-up SERVO-DRIVE for AVENTOS

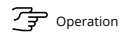

Operation



Lights up continuously



Flashes

A Activating the SERVO-DRIVE switch

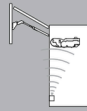

Setting up the wireless connection between the SERVO-DRIVE switch and the drive unit.
Only one SERVO-DRIVE switch can be assigned to each drive unit.

1

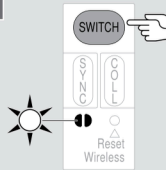

Press the <SWITCH> button until the LED flashes

2

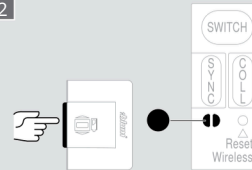

Press the SERVO-DRIVE switch until the LED lights up continuously

3

Repeat procedure A1-2 for additional SERVO-DRIVE switches in the cabinet.

Additional features

Optional

C Activating synchronisation

D Activating collision avoidance

B Starting reference run



The drive unit recognises the required parameters using the reference run.

1

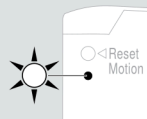

Reference run is required: LED flashes

2

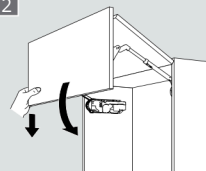

Close the front manually

3

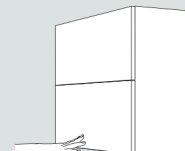

Press on front: The reference run starts automatically

4

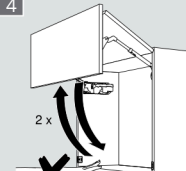

Front opens and closes 2x automatically: Under no circumstances should you try to manually interrupt or stop the process

If the reference run is interrupted, it should be reset – see Reset Motion B1. Restart reference run.

Additional features SERVO-DRIVE for AVENTOS

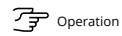

Operation



Lights up continuously



Flashes

C Activating synchronisation



Up to three drive units can be synchronised so that they move simultaneously. This function is required for several cabinets with a uniform front.

1

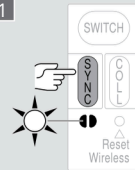

Press the <SYNC> button on the 1st drive unit until the LED flashes

2

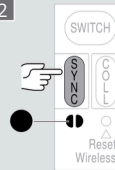

Press <SYNC> on the 2nd drive unit until the LEDs on both synchronised drive units light up continuously

3

Repeat procedure C1-2 for all additional drive units.

D Activating collision avoidance



To avoid the collision of fronts, drive units (max. 6) are linked so that only one front can be opened at a time. A front is prevented from opening as long as a linked front remains open.

1

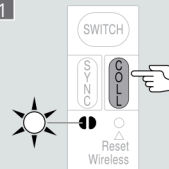

Press the <COLL> button on the 1st drive unit until the LED flashes

2

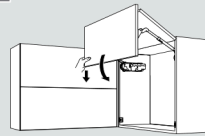

Close the front manually

3

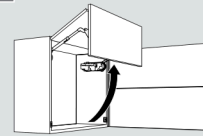

2. Open the front manually

4

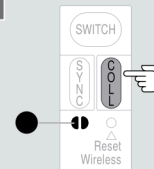

Press <COLL> on the 2nd drive unit until the LED lights up continuously.

5

Repeat procedure D1-4 for all additional cabinets.

Deactivation SERVO-DRIVE for AVENTOS



E Reset motion

Resets the reference run and enables a new reference run to be started.

1

Press the <Reset Motion> button using a pen (at least 3 seconds) until the LED flashes quickly.

F Reset wireless

Deactivates all functions:
All active SERVO-DRIVE switches, synchronisations and collision avoidance settings for the respective drive unit are deleted.

1

Press the <Reset Wireless> button using a pen (at least 3 seconds) until the LED flashes quickly.

Motion LED signals		
	Flashes orange	Reference run is required
	Lights orange continuously	Power available Operating mode display Reference run successfully completed
	Flashes orange quickly	Reset Motion confirmation

Wireless LED signals		
	Flashes green	Activation mode
	Lights up green continuously	Activation confirmation
	Flashes green quickly	Deactivation confirmation
	Lights red continuously	Last process was not completed successfully

Blum



1952



The first product
Studs are attached to horse-shoes to stop horses slipping.

1958



Début in the furniture industry
The ANUBA hinge is Blum's first furniture fitting.

1964



Production start
Blum produces concealed furniture hinges.

1966



Roller runners
Blum starts to produce roller runners.

1985



Assembly technology
CLIP hinges can be mounted without tools thanks to CLIP technology.

Perfecting motion

Blum's fittings solutions are designed to make opening and closing furniture a mesmerising experience. That's why we make every effort to perfect the motion of our lift, hinge, box and runner systems.



DYNAMIC SPACE

Blum products help optimise workflows, produce extra storage space and provide enhanced user convenience – making kitchens extremely practical.

Blum in Austria and around the world

Over 5,000 employees work hard to help us perfect motion. Our fittings are manufactured at ten plants. Seven are in Austria, the remaining are in the USA, Brazil and Poland. Thanks to international subsidiaries and sales agencies, Blum is on site to serve its customers all over the world.



Global customer benefits

Everyone should benefit from the advantages of Blum products – from furniture manufacturers right down to end users.

Top quality

Blum products have been developed for everyday kitchen use and are a pleasure to use a furniture lifetime.



Innovations

We want our fittings solutions to be innovative and make everyday kitchen use easier. That's why our developments are based on findings from requirement research and input from our customers.

Environment

Blum strives to minimise its environmental impact. We use environmentally-friendly processes, use raw materials intelligently and save energy wherever we can.



Our commitment to environmental protection is internationally recognised and rewarded. We endeavour to maintain and are always looking to improve our environmental management systems



1987



BOX systems

Blum's first BOX system goes into production with METABOX.

2001



Soft-close system

BLUMOTION ensures that furniture closes softly and effortlessly.

2005



Lift systems

AVENTOS lift systems are presented for the first time

2007



Electrical opening support system

SERVO-DRIVE has received numerous awards for design and function.

2011

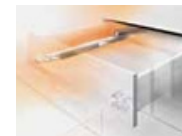

Runner systems

With MOVENTO, a new generation of runner systems was born.

Experience the mesmerising motion
Blum showrooms

Sydney (Head Office)
10 Blackbird Close
Len Waters Estate NWS 2170
Ph: 02 9612 5400

Brisbane
6/39-45 Compton Road
Underwood QLD 4119
Ph: 07 3135 9490

Melbourne
4/245 Ferntree Gully Road
Mount Waverley VIC 3149
Ph: 03 9982 1720

Perth
3/50 Howe Street
Osborne Park WA 6916
Ph: 08 6467 0110

Adelaide
3/277-281 Sir Donald Bradman Drive
Cowandilla SA 5033
Ph: 08 8118 6070



Blum Australia Pty. Ltd.
PO Box 1615
Green Valley, N.S.W 2168
Toll Free: 1800 179 186
Fax: +61 2 9822-8540
E-mail: info.au@blum.com
www.blum.com

The Blum logo features a stylized white arrow pointing upwards and to the right, followed by the word 'blum' in a bold, lowercase, sans-serif font. A registered trademark symbol (®) is located to the upper right of the word.

All content is copyrighted by Blum.
Subject to technical modifications and changes to the range without notice.
Printed in Australia · IDNR: 1.001.39